



FPT300F

Homopolymer Polypropylene

- Good Mold Release, Excellent Part Finish (Low Bloom)
- Suggested Uses Include Housewares, Caps and Closures, Mugs / Cups, Thin-Walled Containers

Property	Units	Typical Value	Test Method
Nominal Melt Flow Rate (230°C/2.16kg)	g/10 min	30	ASTM D1238
Tensile Strength at Yield (2 in/min, 50 mm/min)	psi MPa	4,800 33	ASTM D638
Elongation at Yield (2 in/min, 50 mm/min)	%	10	ASTM D638
Flexural Modulus (0.05 in/min, 1.3 mm/min, 1% secant)	psi MPa	200,000 1,379	ASTM D790A
Notched Izod Impact Strength at 23°C	ft-lbs/in J/m	0.7 37	ASTM D256A
Rockwell Hardness	R	104	ASTM D785

Information contained herein is considered accurate to our best knowledge. It is offered for your consideration and investigation, and is not to be construed as a representation or warranty, expressed or implied, for which Braskem assumes legal responsibility. Our warranties are limited to those expressly stated in formal contracts or in conditions of sale on our invoices and order acceptances. Conditions and methods of use vary and are beyond the control of Braskem. Braskem, therefore, disclaims any liability incurred as a result of the use of its products in accordance with the data contained herein. No information herein shall be construed as an offer of indemnity for infringement or as a recommendation to use these products in such a manner as to infringe any patent, domestic or foreign.

For cautions and other information relating to handling of
and exposure to this product, please see material safety
data sheet code number C4001 published by Braskem.

550 Technology Drive
Pittsburgh, PA 15219
1-800-223-8871

Revision Date: Monday,
March 23, 2009

www.braskem.com

	Raw Material Product Data Sheet	
	Product Name: MRPBK01	Revision #: A
	Revision Date	August 14, 2019
	Effective Date	October 14, 2019

Product Name:

MRPBK01

Product Description:

FDA Compliant black colorant intended to be used with injection-molded plastic resin

Product Data:

Additives None

<u>Typical Properties</u>	<u>Typical Value</u>
Delta E Tolerance	Less than 2.00
Visual Evaluation	Visual match to approved color standard

FDA Compliance/Status

FDA, Title 21 CFR Food & Drug Contact	<input checked="" type="checkbox"/> Compliant	<input type="checkbox"/> Not
---------------------------------------	---	------------------------------

This colorant formulation has been manufactured using FDA approved ingredients and, when used appropriately (with an FDA approved resin), will meet FDA contact applications regulated under the provisions of the Food, Drug, and Cosmetic Act (and subsequent amendments as outlined in Title 21 of the Code of Federal Regulation).

Additional Compliance/Status (and amendments as of the date of this document)

Proposition 65, Safe Drinking Water and Toxic Enforcement Act	<input checked="" type="checkbox"/> Compliant	<input type="checkbox"/> Not
CONEG, Model Toxics in Packaging Legislation	<input checked="" type="checkbox"/> Compliant	<input type="checkbox"/> Not
EU 2015/863, as regards the list of restricted substances, RoHS	<input checked="" type="checkbox"/> Compliant	<input type="checkbox"/> Not

For further regulatory information, please contact Mold Rite Plastic's customer service or sales department.

This product data sheet addresses all colorants that meet the above requirements & specifications. Data was obtained from supplier product data sheets (where applicable). This data is intended to be used as a guide only. It is ultimately the customer's responsibility to determine the suitability of the material for their specific application, and to be responsible for assuring compliance with all applicable laws and regulations.



Product Data Sheet

MRP Description: (A01)MRPLN04.020 FOAM R SFYP

MRPLN04 – Universal Heat Seal Foam Liner

Product Description

This product is a 1 piece universal heat seal consisting of foam backing, paper, aluminum foil and heat seal layer.. This specification, designated by Mold-Rite Plastics, covers all liners that meet the typical value data listed below;

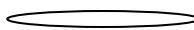
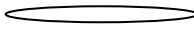
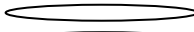
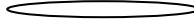
-  Polystyrene Foam
-  Paper
-  Aluminum Foil
-  Heat Seal Coating

Regulatory Compliance

FDA Title 21 CFR Section 177.1210 (Closure with Sealing Gaskets for Food Containers,
 RoHS Compliant
 CONEG/Heavy Metal Compliant
 Proposition 65 Compliant

Typical Properties	Typical Value
Overall Thickness	.024 +/- 10%
Drug Master File	16574
Printed	R SFYP
Oxygen Transmission	Essentially Zero
Water Vapor Transmission	Essentially Zero

For further regulatory information, contact Mold-Rite Plastics customer service or sales department.

Notes: These are typical properties not to be construed as specifications. Mold-Rite Plastics reserves that right to include any other liner that meets that above data values and regulatory requirements.

This product data sheet covers multiple liners that meet the above typical data values and regulatory requirements. All listed liners have similar physical, chemical and processing properties. Listed known liners: HS035, HS 035N, HS205, FS5-8, HSS-5.6

All results were obtained from manufacturer product data sheets (where applicable). The data are intended as a general guide only and do not necessarily represent results that may be obtained elsewhere. The use of Mold-Rite Plastics products must be guided by the users own methods for selection of proper formulation. Mold-Rite Plastics disclaims any responsibility for misuse or miss application of its products. Mold-Rite Plastics liability and customer's exclusive remedy for any claims arising out of sales of its products are expressly limited at customer option for replacement not to exceed the purchase price plus transportation charges thereon in respect to any material which damage is claimed.

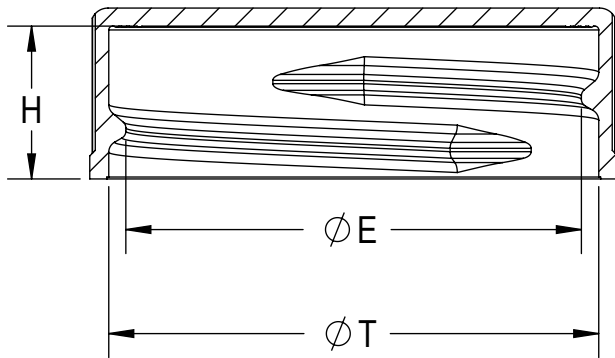
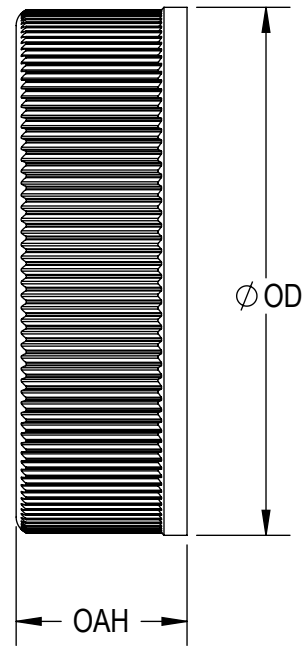
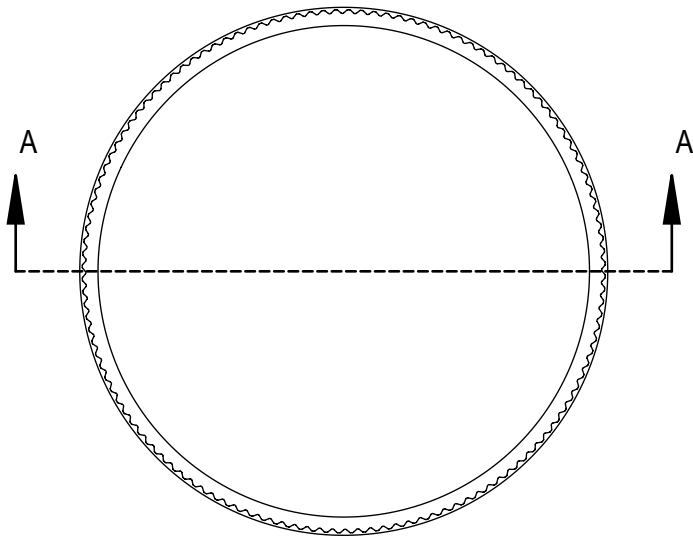

SECTION A-A
SCALE 2 : 1

THREAD DETAIL INFORMATION:
6 THREADS PER INCH, 0.167" PITCH

REFERENCE	TOLERANCE	UNITS	DIMENSION
E	±0.010 [0.25]	in [mm]	1.182 [30.02]
T	±0.010 [0.25]	in [mm]	1.276 [32.41]
H	±0.010 [0.25]	in [mm]	0.398 [10.11]
OAH	±0.010 [0.25]	in [mm]	0.445 [11.3]
OD	±0.010 [0.25]	in [mm]	1.375 [34.93]
PART WEIGHT	±0.30	g	2.10

STATIC TORQUE RECOMMENDATION
15-25 in-lbs
THIS REQUIREMENT MAY VARY DEPENDING
UPON BOTTLE MATERIAL, NECK FINISH, AND
CAPPING EQUIPMENT

DRAWING TYPE : CUSTOMER

REPLACES DRAWINGS:
C-3007

DIMENSIONS ENCLOSED IN ()
INDICATE REFERENCE
DIMENSIONS AND NO TOLERANCE
LIMITS ARE ESTABLISHED

TOLERANCES UNLESS OTHERWISE SPECIFIED

DIMENSION (inches)	TOLERANCE	DIMENSION (mm)	TOLERANCE
0-0.787	±0.006	0-20	±0.152
0.788-1.181	±0.008	21-30	±0.203
1.182-2.756	±0.012	31-70	±0.305
2.757-3.937	±0.016	71-100	±0.406
3.938-5.096	±0.020	101-150	±0.508
5.097-7.874	±0.024	151-200	±0.610
7.875-9.843	±0.032	201-250	±0.813

ANGULAR TOLERANCE ± 2°

PROPRIETARY AND CONFIDENTIAL

THIS DRAWING IS PROTECTED BY COPYRIGHT AND CONTAINS INFORMATION
PROPRIETARY TO MOLD-RITE, WEATHERCHEM AND STULL TECHNOLOGIES.
ANY REPRODUCTION, DISCLOSURE, OR USE OF ITS CONTENTS OR ANY PART
THEREOF IS EXPRESSLY PROHIBITED EXCEPT AS MOLD-RITE, WEATHERCHEM
AND STULL TECHNOLOGIES OTHERWISE MAY AGREE IN WRITING

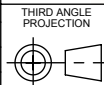

DISTRIBUTION
CODE
D

DRAWING NAME
**33-400 CT
RS (RIBBED SIDES, SMOOTH TOP)**

DRAWING NUMBER
CQA - 10040

MATERIAL
POLYPROPYLENE

MODEL NUMBER:
PM 10674 33-400 CT

DRAWN BY: DAS 4/6/2017

ENG APPR: JDM 5/5/2017

QA APPR: ADP 05/05/2017

SCALE	SHEET SIZE	SHEET	REV NP
1:1	8.5in*11in	1 of 3	00.AA

THE CLOSURE DIMENSIONS
DEPICTED ARE THOSE WHICH HAVE GENERALLY BEEN
FOUND TO BE FUNCTIONAL BASED ON INDUSTRY
EXPERIENCE BECAUSE OF VARIABILITY IN GLASS AND
PLASTIC CONTAINER FINISHES, EACH CLOSURE/FINISH
SYSTEM SHOULD BE INDIVIDUALLY EVALUATED AND
TESTED TO ENSURE IT MEETS APPLICABLE
PERFORMANCE CRITERIA. SEE QUALITY ASSURANCE
SPECIFICATIONS FOR ADDITIONAL INFORMATION.

MOLD-RITE, WEATHERCHEM AND STULL TECHNOLOGIES
RESERVES THE RIGHT TO REVISE ANY OR ALL
SPECIFICATIONS AND REQUIREMENTS.

REVISIONS						
DATE	REV	N/P	PRODUCT DRAWING REQUEST	DESCRIPTION	ENG	DRW
04/03/2017	00	AA	17-019	UPDATED DRAWING FORMAT	BDG	DAS

SMOOTH TOP RIBBED SIDES

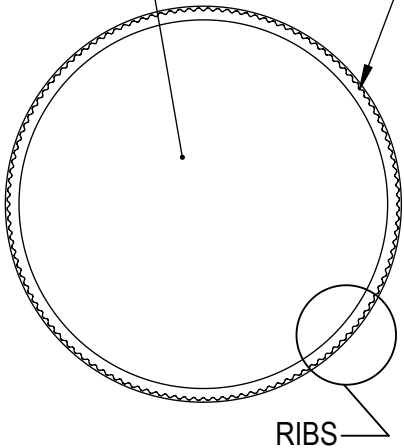

RIBS

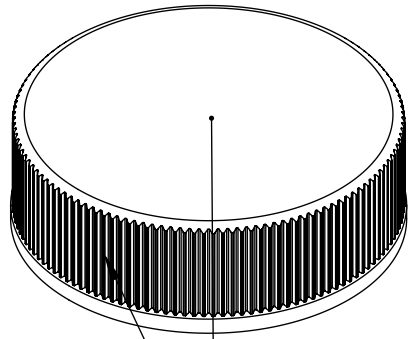

OPTIONAL GATE LOCATION
(SEE TABLE BELOW)

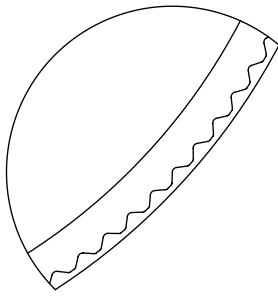

DETAIL RIBS
SCALE 5 : 1

MOLD NUMBER	GATE LOCATION
33001	SIDE
33003	SIDE
33010	SIDE
33014	TOP CENTER

DRAWING TYPE : CUSTOMER			
REFERENCES: 33001, 33003, 33010, 33014		DIMENSIONS ENCLOSED IN () INDICATE REFERENCE DIMENSIONS AND NO TOLERANCE LIMITS ARE ESTABLISHED	
TOLERANCES UNLESS OTHERWISE SPECIFIED			
DIMENSION (inches)	TOLERANCE	DIMENSION (mm)	TOLERANCE
0-0.787	±0.006	0-20	±0.152
0.788-1.181	±0.008	21-30	±0.203
1.182-2.756	±0.012	31-70	±0.305
2.757-3.937	±0.016	71-100	±0.406
3.938-5.096	±0.020	101-150	±0.508
5.097-7.874	±0.024	151-200	±0.610
7.875-9.843	±0.032	201-250	±0.813
ANGULAR TOLERANCE ± 2°			
PROPRIETARY AND CONFIDENTIAL			
THIS DRAWING IS PROTECTED BY COPYRIGHT AND CONTAINS INFORMATION PROPRIETARY TO MOLD-RITE, WEATHERCHEM AND STULL TECHNOLOGIES. ANY REPRODUCTION, DISCLOSURE, OR USE OF ITS CONTENTS OR ANY PART THEREOF IS EXPRESSLY PROHIBITED EXCEPT AS MOLD-RITE, WEATHERCHEM AND STULL TECHNOLOGIES OTHERWISE MAY AGREE IN WRITING			

THE CLOSURE DIMENSIONS
DEPICTED ARE THOSE WHICH HAVE GENERALLY BEEN
FOUND TO BE FUNCTIONAL BASED ON INDUSTRY
EXPERIENCE BECAUSE OF VARIABILITY IN GLASS AND
PLASTIC CONTAINER FINISHES. EACH CLOSURE/FINISH
SYSTEM SHOULD BE INDIVIDUALLY EVALUATED AND
TESTED TO ENSURE IT MEETS APPLICABLE
PERFORMANCE CRITERIA. SEE QUALITY ASSURANCE
SPECIFICATIONS FOR ADDITIONAL INFORMATION.
MOLD-RITE, WEATHERCHEM AND STULL TECHNOLOGIES
RESERVES THE RIGHT TO REVISE ANY OR ALL
SPECIFICATIONS AND REQUIREMENTS.



THIRD ANGLE PROJECTION		DISTRIBUTION CODE D		DRAWING NAME 33-400 CT RS (RIBBED SIDES, SMOOTH TOP)			
DRAWN BY: DAS		4/6/2017		DRAWING NUMBER CQA - 10040			
ENG APPR: JDM		5/5/2017		MATERIAL POLYPROPYLENE			
QA APPR: ADP		05/05/2017		MODEL NUMBER: PM 10674 33-400 CT			
SCALE 3:2		SHEET SIZE 8.5 X 11		SHEET 2 of 3		REV.NP 00.AA	

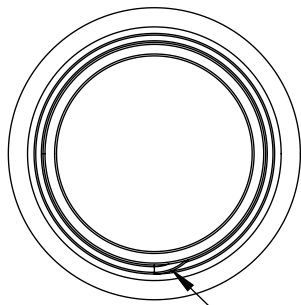

THREAD START

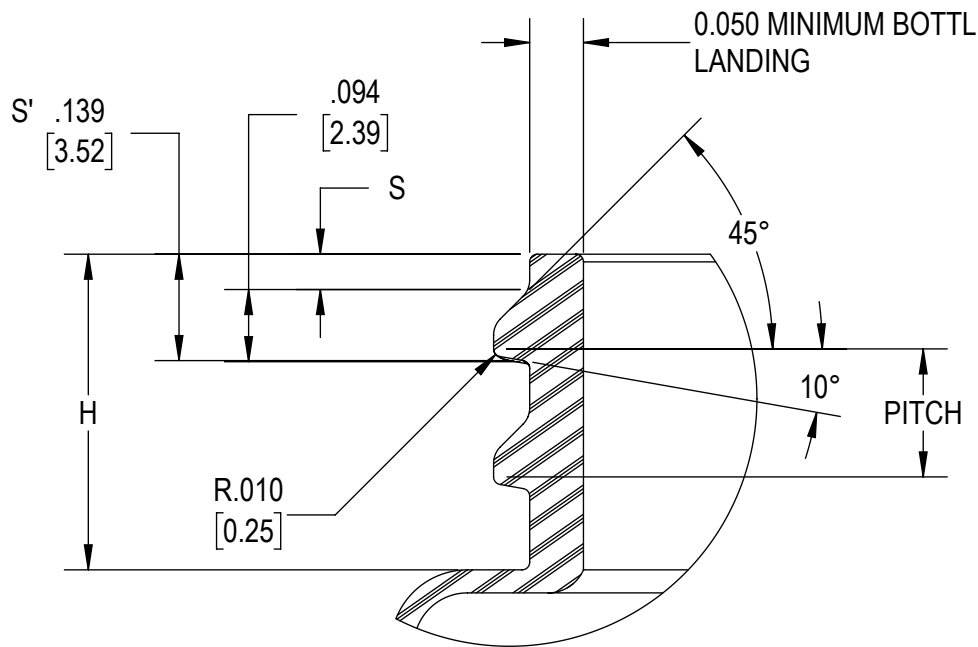

DETAIL THREAD
SCALE 4 : 1

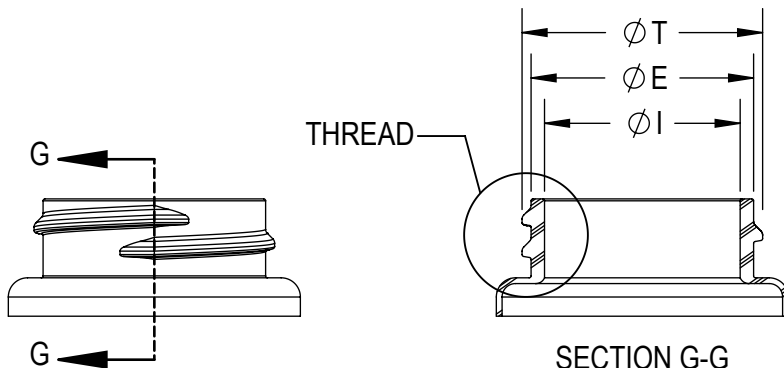

SECTION G-G

REFERENCE	TOLERANCE	UNITS	DIMENSION
E	±0.012 [0.30]	in [mm]	1.159 [29.44]
T	±0.012 [0.30]	in [mm]	1.253 [31.83]
I	MINIMUM	in [mm]	0.791 [20.09]
S	±0.015 [0.38]	in [mm]	0.046 [1.17]
H	±0.015 [0.38]	in [mm]	0.403 [10.24]
PITCH		in [mm]	0.167
TPI			6

NOTE: THE NOMINAL ORIENTATION ILLUSTRATED IS BASED ON NOMINAL DIMENSIONS OF BOTH THE CLOSURE AND THE RECOMMENDED NECK FINISH. FOR EXACT ORIENTATION EACH BOTTLE SHOULD BE EVALUATED ON A CASE BY CASE BASIS.

DRAWING TYPE : CUSTOMER

DIMENSIONS ENCLOSED IN () INDICATE REFERENCE DIMENSIONS AND NO TOLERANCE LIMITS ARE ESTABLISHED

TOLERANCES UNLESS OTHERWISE SPECIFIED

DIMENSION (inches)	TOLERANCE	DIMENSION (mm)	TOLERANCE
0-0.787	±0.006	0-20	±0.152
0.788-1.181	±0.008	21-30	±0.203
1.182-2.756	±0.012	31-70	±0.305
2.757-3.937	±0.016	71-100	±0.406
3.938-5.096	±0.020	101-150	±0.508
5.097-7.874	±0.024	151-200	±0.610
7.875-9.843	±0.032	201-250	±0.813

ANGULAR TOLERANCE ± 2°

PROPRIETARY AND CONFIDENTIAL

THIS DRAWING IS PROTECTED BY COPYRIGHT AND CONTAINS INFORMATION PROPRIETARY TO MOLD-RITE, WEATHERCHEM AND STULL TECHNOLOGIES. ANY REPRODUCTION, DISCLOSURE, OR USE OF ITS CONTENTS OR ANY PART THEREOF IS EXPRESSLY PROHIBITED EXCEPT AS MOLD-RITE, WEATHERCHEM AND STULL TECHNOLOGIES OTHERWISE MAY AGREE IN WRITING



SOLIDWORKS

D

DISTRIBUTION CODE

DRAWING NAME

33-400 CT
RECOMMENDED NECK FINISH

DRAWING NUMBER

CQA - 10040

DRAWN BY.

DAS

4/6/2017

MATERIAL

ENG APPR.

JDM

5/5/2017

MODEL NUMBER:

QA APPR.

ADP

05/05/2017

SCALE

1:1

SHEET SIZE

8.5 X 11

SHEET

3 of 3

REV/N/P

00.AA

THE CLOSURE DIMENSIONS DEPICTED ARE THOSE WHICH HAVE GENERALLY BEEN FOUND TO BE FUNCTIONAL BASED ON INDUSTRY EXPERIENCE BECAUSE OF VARIABILITY IN GLASS AND PLASTIC CONTAINER FINISHES, EACH CLOSURE/FINISH SYSTEM SHOULD BE INDIVIDUALLY EVALUATED AND TESTED TO ENSURE IT MEETS APPLICABLE PERFORMANCE CRITERIA. SEE QUALITY ASSURANCE SPECIFICATIONS FOR ADDITIONAL INFORMATION.

MOLD-RITE, WEATHERCHEM AND STULL TECHNOLOGIES RESERVES THE RIGHT TO REVISE ANY OR ALL SPECIFICATIONS AND REQUIREMENTS.