



FPT300F

Homopolymer Polypropylene

- Good Mold Release, Excellent Part Finish (Low Bloom)
- Suggested Uses Include Housewares, Caps and Closures, Mugs / Cups, Thin-Walled Containers

Property	Units	Typical Value	Test Method
Nominal Melt Flow Rate (230°C/2.16kg)	g/10 min	30	ASTM D1238
Tensile Strength at Yield (2 in/min, 50 mm/min)	psi MPa	4,800 33	ASTM D638
Elongation at Yield (2 in/min, 50 mm/min)	%	10	ASTM D638
Flexural Modulus (0.05 in/min, 1.3 mm/min, 1% secant)	psi MPa	200,000 1,379	ASTM D790A
Notched Izod Impact Strength at 23°C	ft-lbs/in J/m	0.7 37	ASTM D256A
Rockwell Hardness	R	104	ASTM D785

Information contained herein is considered accurate to our best knowledge. It is offered for your consideration and investigation, and is not to be construed as a representation or warranty, expressed or implied, for which Braskem assumes legal responsibility. Our warranties are limited to those expressly stated in formal contracts or in conditions of sale on our invoices and order acceptances. Conditions and methods of use vary and are beyond the control of Braskem. Braskem, therefore, disclaims any liability incurred as a result of the use of its products in accordance with the data contained herein. No information herein shall be construed as an offer of indemnity for infringement or as a recommendation to use these products in such a manner as to infringe any patent, domestic or foreign.

For cautions and other information relating to handling of
and exposure to this product, please see material safety
data sheet code number C4001 published by Braskem.

550 Technology Drive
Pittsburgh, PA 15219
1-800-223-8871

Revision Date: Monday,
March 23, 2009

www.braskem.com

	Raw Material Product Data Sheet	
	Product Name: MRPWH01	Revision #: A
	Revision Date	03/07/2019
	Effective Date	07/01/2019

Product Name:

MRPWH01

Product Description:

FDA Compliant White colorant, intended to be used with injection-molded plastic resin

Product Data:

Additives None

<u>Typical Properties</u>	<u>Typical Value</u>
Delta E Tolerance	Less than 2.00
Visual Evaluation	Visual match to approved color standard

FDA Compliance/Status

FDA, Title 21 CFR Food & Drug Contact	<input checked="" type="checkbox"/> Compliant	<input type="checkbox"/> Not
---------------------------------------	---	------------------------------

This colorant formulation has been manufactured using FDA approved ingredients and, when used appropriately (with an FDA approved resin), will meet FDA contact applications regulated under the provisions of the Food, Drug, and Cosmetic Act (and subsequent amendments as outlined in Title 21 of the Code of Federal Regulation.

Additional Compliance/Status (and amendments as of the date of this document)

Proposition 65, Safe Drinking Water and Toxic Enforcement Act	<input checked="" type="checkbox"/> Compliant	<input type="checkbox"/> Not
CONEG, Model Toxics in Packaging Legislation	<input checked="" type="checkbox"/> Compliant	<input type="checkbox"/> Not
EU 2015/863, as regards the list of restricted substances, RoHS	<input checked="" type="checkbox"/> Compliant	<input type="checkbox"/> Not

For further regulatory information, please contact Mold Rite Plastic's customer service or sales department.

This product data sheet addresses all colorants that meet the above requirements & specifications. Data was obtained from supplier product data sheets (where applicable). This data is intended to be used as a guide only. It is ultimately the customer's responsibility to determine the suitability of the material for their specific application, and to be responsible for assuring compliance with all applicable laws and regulations.



Freshness and Protection
for Today's Packaging

FoilSeal™ Data Sheet

.008" C1S FS5-4

Revision: FS54-01182007

MRP Description -
(854)FS5-4/C1S.008 R SFYP

Product	.008" C1S FS5-4																	
Scope	One piece board backed heat induction foil innerseal which combines ease of removal with tamper-evident properties. It is suggested for sealing to polyethylene, polypropylene, PET, PVC, polystyrene and properly treated glass containers. This material will vent gas through the paper layer and is suggested for use on dry products only.																	
Composition	<table border="1"> <thead> <tr> <th>Material</th> <th>Standard</th> <th>Metric</th> </tr> </thead> <tbody> <tr> <td>Backing</td> <td>.008"</td> <td>.2032mm</td> </tr> <tr> <td>Foil</td> <td>.001"</td> <td>.0254mm</td> </tr> <tr> <td>Paper</td> <td>.002"</td> <td>.0508mm</td> </tr> <tr> <td>Heat Seal</td> <td>.0015"</td> <td>.0381mm</td> </tr> </tbody> </table>	Material	Standard	Metric	Backing	.008"	.2032mm	Foil	.001"	.0254mm	Paper	.002"	.0508mm	Heat Seal	.0015"	.0381mm		
Material	Standard	Metric																
Backing	.008"	.2032mm																
Foil	.001"	.0254mm																
Paper	.002"	.0508mm																
Heat Seal	.0015"	.0381mm																
Composition does not include adhesive, resin or wax bonding layers (if any).																		
FDA Status:	21 CFR 177.1210	Recommended Storage and Handling:																
Drug Master File (DFM):	#4544	Print Locatoin (if any): Heat Seal Layer and/or Backing																
GTR Oxygen: 11.0 cc's/100 Sq.in./24 hrs.	MVTR: .009 gms/100 Sq.in./24 hrs.	Canadian DMF:	EU / EP Reg.:															
<p>Sealing to glass containers: Selig can not guarantee the performance or seal integrity of this materials when applied to any glass (treated or untreated) container. We suggest you contact your glass supplier for recommendations on glass treatments that may or may not improve performance or seal integrity.</p>																		

Selig materials are compliant with current USFDA Food allergen Guidelines.
Selig materials are compliant with California Proposition 65 labeling requirements.
Selig materials are compliant with limitation of heavy metals in packaging per CONEG & EU 94/62/EC, article 11.

MSDS's are not required as Selig is not a chemical manufacturer or distributor and our products are 'articles' intended for food packaging per 29 CFR 1910.1200 (HazCom).

The information contained within this product data bulletin is to be used as a general guide in determining which structures are offered for sealing to specific container materials. All of the information which we provide is reliable to the best of our knowledge, but the accuracy thereof is not guaranteed. We suggest that consumers determine suitability for their own application.

Manufacturing & Customer Service:

342 E. Wabash St.
Forrest, IL 61741, USA
Phone: +1 (815) 657-8233
Fax: +1 (815) 657-7584

North American Sales:

2132 Deep Water Lane
Naperville, IL 60564, USA
Phone: +1 (630) 922-3158
Fax: +1 (630) 922-8469
www.seligsealing.com

Selig Europe:

Warrington Road
High Legh
Nr Knutsford
Cheshire WA16 0RT
Telephone: +44 (0)1925 752600
Fax: +44 (0)1925 757527



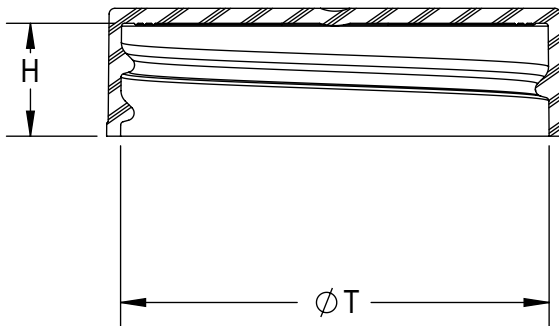
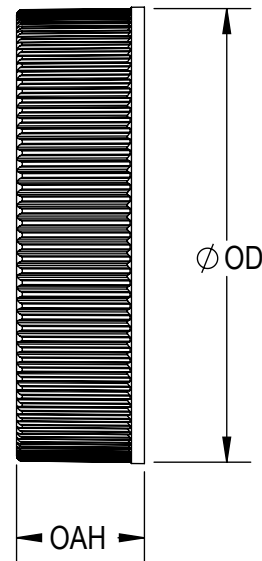
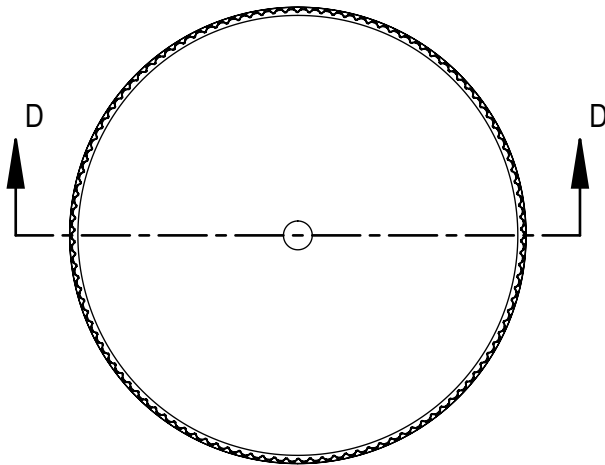

SECTION D-D

THREAD DETAIL INFORMATION
6 THREADS PER INCH, 0.167 PITCH

REFERENCE	TOLERANCE	DIMENSION	UNITS
E	±0.010 [0.25]	1.394 [35.41]	in [mm]
T	±0.010 [0.25]	1.488 [37.80]	in [mm]
H	±0.008 [0.20]	0.392 [9.96]	in [mm]
OAH	±0.008 [0.20]	0.444 [11.28]	in [mm]
OD	±0.015 [0.38]	1.590 [40.39]	in [mm]
PART WEIGHT	± 0.30	2.85	g

STATIC TORQUE RECOMMENDATION
17-26 in-lbs
THIS REQUIREMENT MAY VARY DEPENDING
UPON BOTTLE MATERIAL, NECK FINISH, AND
CAPPING EQUIPMENT

DRAWING TYPE : CUSTOMER

REPLACES DRAWINGS:
C-3008

DIMENSIONS ENCLOSED IN ()
INDICATE REFERENCE
DIMENSIONS AND NO TOLERANCE
LIMITS ARE ESTABLISHED

TOLERANCES UNLESS OTHERWISE SPECIFIED

DIMENSION (inches)	TOLERANCE	DIMENSION (mm)	TOLERANCE
0-0.787	±0.006	0-20	±0.152
0.788-1.181	±0.008	21-30	±0.203
1.182-2.756	±0.012	31-70	±0.305
2.757-3.937	±0.016	71-100	±0.406
3.938-5.096	±0.020	101-150	±0.508
5.097-7.874	±0.024	151-200	±0.610
7.875-9.843	±0.032	201-250	±0.813

ANGULAR TOLERANCE ± 2°

PROPRIETARY AND CONFIDENTIAL

THIS DRAWING IS PROTECTED BY COPYRIGHT AND CONTAINS INFORMATION
PROPRIETARY TO MOLD-RITE, WEATHERCHEM AND STULL TECHNOLOGIES.
ANY REPRODUCTION, DISCLOSURE, OR USE OF ITS CONTENTS OR ANY PART
THEREOF IS EXPRESSLY PROHIBITED EXCEPT AS MOLD-RITE, WEATHERCHEM
AND STULL TECHNOLOGIES OTHERWISE MAY AGREE IN WRITING

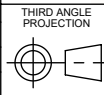

DISTRIBUTION
CODE
D

DRAWING NAME
**38-400 CT CLOSURE
RS (Ribbed - Smooth)**

DRAWING NUMBER
CQA - 10015

MATERIAL
POLYPROPYLENE

MODEL NUMBER:
PM 10498 38-400 CT

DRAWN BY: DAS 5/5/2017

ENG APPR: Admin 1/11/2019

QA APPR: Admin 01/11/2019

SCALE	SHEET SIZE	SHEET	REV.NP
3:2	8.5in*11in	1 of 3	00.AC

THE CLOSURE DIMENSIONS
DEPICTED ARE THOSE WHICH HAVE GENERALLY BEEN
FOUND TO BE FUNCTIONAL BASED ON INDUSTRY
EXPERIENCE BECAUSE OF VARIABILITY IN GLASS AND
PLASTIC CONTAINER FINISHES, EACH CLOSURE/FINISH
SYSTEM SHOULD BE INDIVIDUALLY EVALUATED AND
TESTED TO ENSURE IT MEETS APPLICABLE
PERFORMANCE CRITERIA. SEE QUALITY ASSURANCE
SPECIFICATIONS FOR ADDITIONAL INFORMATION.

MOLD-RITE, WEATHERCHEM AND STULL TECHNOLOGIES
RESERVES THE RIGHT TO REVISE ANY OR ALL
SPECIFICATIONS AND REQUIREMENTS.

REVISIONS

DATE	REV.	N/P	DESCRIPTION	ENG	DRW
2/26/2014	00	AA	INITIAL RELEASE	CM	LB
4/12/2017	00	AB	UPDATED DRAWING FORMAT	JDM	DAS
12/20/2018	00	AC	DRAWING UPDATED TO REFLECT HISTORICAL RUN DATA & PROCESS CAPABILITY. NO CHANGES TO THE STEEL OR PART HAVE OCCURED. UPDATED RNF TO MATCH PRODUCT SPECIFICATIONS	BDG	AMK

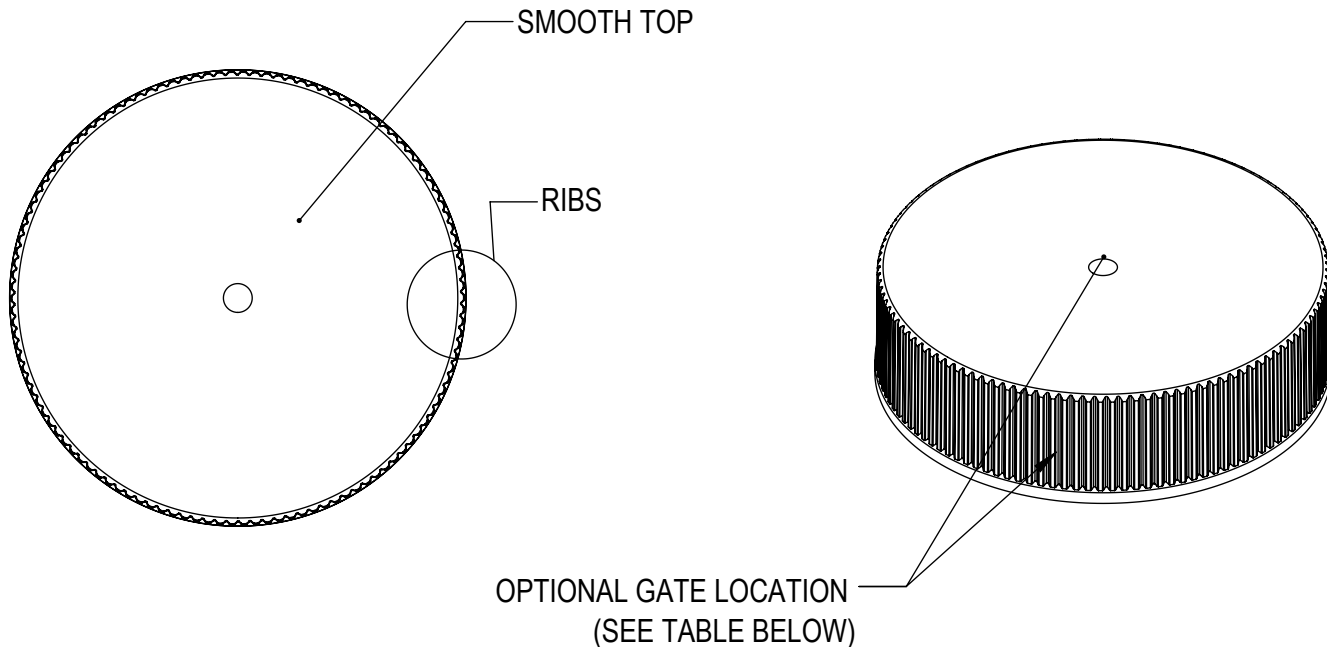

MOLD NUMBER	GATE LOCATION
38003	SIDE
38004	SIDE
38011	SIDE
38012	SIDE
38015	SIDE
38016	SIDE
38024	SIDE
38025	SIDE
38030	TOP CENTER

DETAIL RIBS
SCALE 5 : 1

DRAWING TYPE : CUSTOMER			
REFERENCES: 38003, 38004, 38011, 38012, 38015, 38016, 38024, 38025, 38030		DIMENSIONS ENCLOSED IN () INDICATE REFERENCE DIMENSIONS AND NO TOLERANCE LIMITS ARE ESTABLISHED	
TOLERANCES UNLESS OTHERWISE SPECIFIED			
DIMENSION (inches)	TOLERANCE	DIMENSION (mm)	TOLERANCE
0-0.787	±0.006	0-20	±0.152
0.788-1.181	±0.008	21-30	±0.203
1.182-2.756	±0.012	31-70	±0.305
2.757-3.937	±0.016	71-100	±0.406
3.938-5.096	±0.020	101-150	±0.508
5.097-7.874	±0.024	151-200	±0.610
7.875-9.843	±0.032	201-250	±0.813
ANGULAR TOLERANCE ± 2°			
PROPRIETARY AND CONFIDENTIAL			
THIS DRAWING IS PROTECTED BY COPYRIGHT AND CONTAINS INFORMATION PROPRIETARY TO MOLD-RITE, WEATHERCHEM AND STULL TECHNOLOGIES. ANY REPRODUCTION, DISCLOSURE, OR USE OF ITS CONTENTS OR ANY PART THEREOF IS EXPRESSLY PROHIBITED EXCEPT AS MOLD-RITE, WEATHERCHEM AND STULL TECHNOLOGIES OTHERWISE MAY AGREE IN WRITING			



THE CLOSURE DIMENSIONS DEPICTED ARE THOSE WHICH HAVE GENERALLY BEEN FOUND TO BE FUNCTIONAL BASED ON INDUSTRY EXPERIENCE BECAUSE OF VARIABILITY IN GLASS AND PLASTIC CONTAINER FINISHES. EACH CLOSURE/FINISH SYSTEM SHOULD BE INDIVIDUALLY EVALUATED AND TESTED TO ENSURE IT MEETS APPLICABLE PERFORMANCE CRITERIA. SEE QUALITY ASSURANCE SPECIFICATIONS FOR ADDITIONAL INFORMATION.

MOLD-RITE, WEATHERCHEM AND STULL TECHNOLOGIES RESERVES THE RIGHT TO REVISE ANY OR ALL SPECIFICATIONS AND REQUIREMENTS.

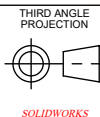

THIRD ANGLE PROJECTION	DISTRIBUTION CODE	DRAWING NAME
	D	38-400 CT CLOSURE RS (Ribbed - Smooth)
		DRAWING NUMBER
		CQA - 10015
DRAWN BY.	DAS	5/5/2017
ENG APPR.	Admin	1/11/2019
QA APPR.	Admin	01/11/2019

MATERIAL			
POLYPROPYLENE			
MODEL NUMBER:			
PM 10498 38-400 CT			
SCALE	SHEET SIZE	SHEET	REV.NP
3:2	8.5 X 11	2 of 3	00.AC

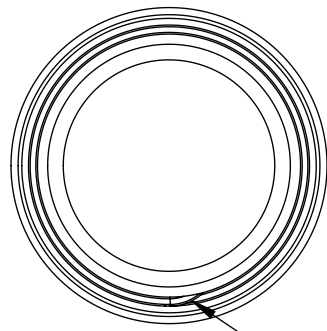

THREAD START

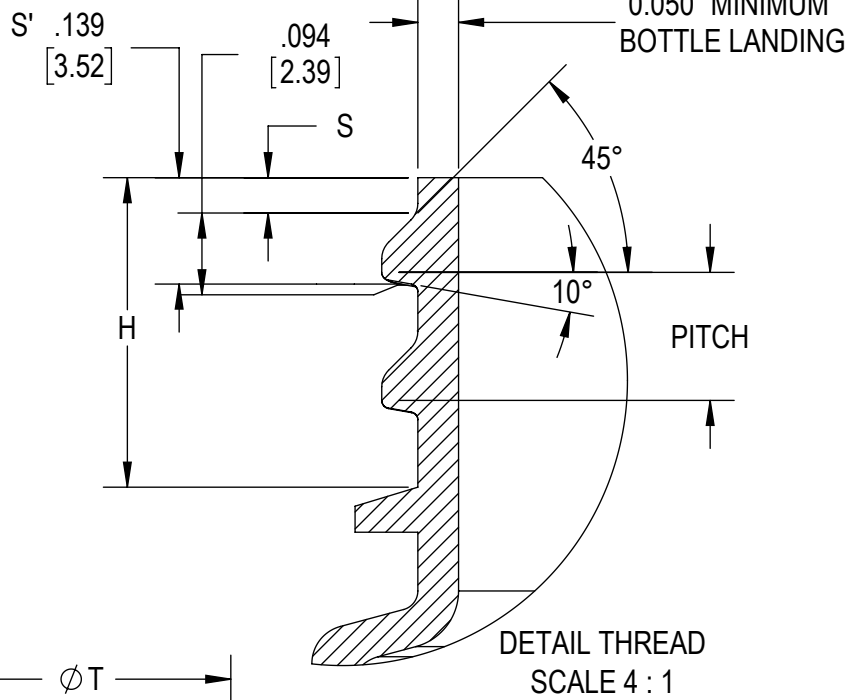

DETAIL THREAD
SCALE 4 : 1

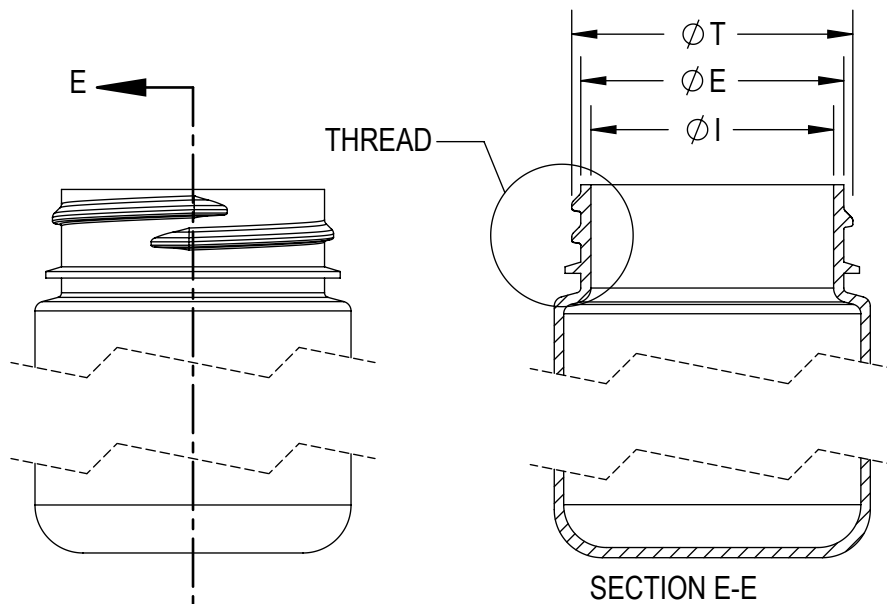

SECTION E-E

REFERENCE	TOLERANCE	UNITS	DIMENSIONS
E	±0.012 [0.30]	in [mm]	1.370 [34.80]
T	±0.012 [0.30]	in [mm]	1.464 [37.19]
I	MINIMUM	in [mm]	0.987 [25.07]
S	±0.015 [0.38]	in [mm]	0.046 [1.17]
H	MINIMUM	in [mm]	0.407 [10.34]
PITCH		in [mm]	0.167 [4.24]
TPI			6

NOTE: THE NOMINAL ORIENTATION ILLUSTRATED IS BASED ON NOMINAL DIMENSIONS OF BOTH THE CLOSURE AND THE RECOMMENDED NECK FINISH. FOR EXACT ORIENTATION EACH BOTTLE SHOULD BE EVALUATED ON A CASE BY CASE BASIS.

DRAWING TYPE : CUSTOMER

DIMENSIONS ENCLOSED IN () INDICATE REFERENCE DIMENSIONS AND NO TOLERANCE LIMITS ARE ESTABLISHED

TOLERANCES UNLESS OTHERWISE SPECIFIED

DIMENSION (inches)	TOLERANCE	DIMENSION (mm)	TOLERANCE
0-0.787	±0.006	0-20	±0.152
0.788-1.181	±0.008	21-30	±0.203
1.182-2.756	±0.012	31-70	±0.305
2.757-3.937	±0.016	71-100	±0.406
3.938-5.096	±0.020	101-150	±0.508
5.097-7.874	±0.024	151-200	±0.610
7.875-9.843	±0.032	201-250	±0.813

ANGULAR TOLERANCE ± 2°

PROPRIETARY AND CONFIDENTIAL

THIS DRAWING IS PROTECTED BY COPYRIGHT AND CONTAINS INFORMATION PROPRIETARY TO MOLD-RITE, WEATHERCHEM AND STULL TECHNOLOGIES. ANY REPRODUCTION, DISCLOSURE, OR USE OF ITS CONTENTS OR ANY PART THEREOF IS EXPRESSLY PROHIBITED EXCEPT AS MOLD-RITE, WEATHERCHEM AND STULL TECHNOLOGIES OTHERWISE MAY AGREE IN WRITING



SOLIDWORKS

DISTRIBUTION CODE

D

DRAWING NAME

38-400 CT CLOSURE
RECOMMENDED NECK FINISH

DRAWING NUMBER

CQA - 10015

MATERIAL

MODEL NUMBER:

DRAWN BY: DAS

5/5/2017

ENG APPR: Admin

1/11/2019

QA APPR: Admin

01/11/2019

SCALE	SHEET SIZE	SHEET	REV/N/P
1:1	8.5 X 11	3 of 3	00.AC

THE CLOSURE DIMENSIONS DEPICTED ARE THOSE WHICH HAVE GENERALLY BEEN FOUND TO BE FUNCTIONAL BASED ON INDUSTRY EXPERIENCE BECAUSE OF VARIABILITY IN GLASS AND PLASTIC CONTAINER FINISHES, EACH CLOSURE/FINISH SYSTEM SHOULD BE INDIVIDUALLY EVALUATED AND TESTED TO ENSURE IT MEETS APPLICABLE PERFORMANCE CRITERIA. SEE QUALITY ASSURANCE SPECIFICATIONS FOR ADDITIONAL INFORMATION.

MOLD-RITE, WEATHERCHEM AND STULL TECHNOLOGIES RESERVES THE RIGHT TO REVISE ANY OR ALL SPECIFICATIONS AND REQUIREMENTS.