

K

MARK	REVISER	DESCRIRTN	DATE

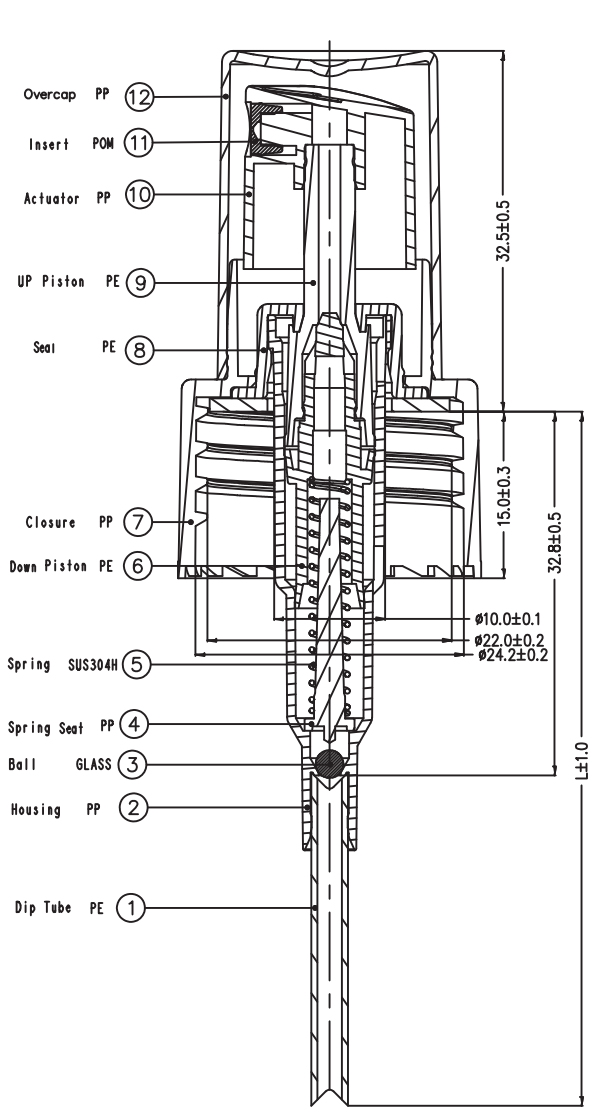

Section A-A

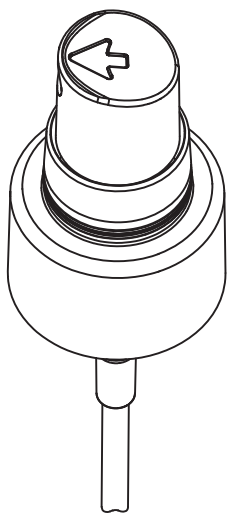
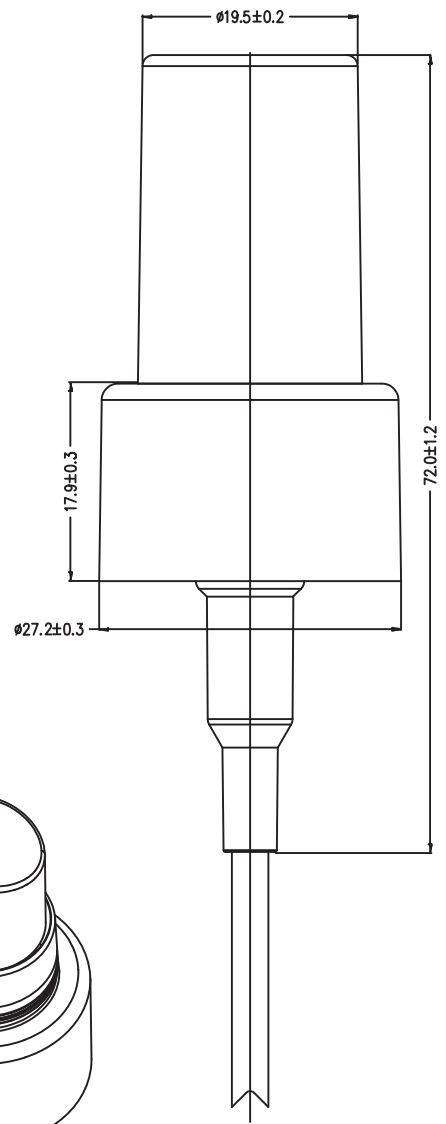

Discharge Rate: $0.20 \pm 0.02 \text{ ml/T}$

F	TOLERANCE			○	DRAFTER:	UNIT: mm	TITLE:	Q'TY:	REV:
	0mm-15mm	±0.05	±0.10	±0.50					
	15mm-30mm	±0.05	±0.15	±1.00	CHECKED:	MODEL NAME:	0613	1/1	A0
	30mm-50mm	±0.10	±0.20	±1.50					
	50mm-99mm	±0.15	±0.30	±2.00	SENSOR:	SCALE:	VISUAL ANGLE	FILE NO:	D-
	ABOVE 99mm	±0.20	±0.40	±2.50					
	CENTER	±0.10	±0.50	±1.00	APPROVED:	PART NO:			
	ANGLER	±0.25°	±0.50°	±2.00°					