

# PRODUCT DATA SHEET

## HS035//35WLP

- HS035//35WLP is a two-piece, pulp backed, induction heat seal and liner with an Ethylene-Vinyl Acetate (EVA) based sealant layer that gives a tamper evident bond to Polyethylene (PE), Polypropylene (PP), Polyester (PET), Polystyrene (PS), Vinyl (PVC) and glass containers.
- Available with standard or custom print.

### Typical Product Attributes

#### Construction

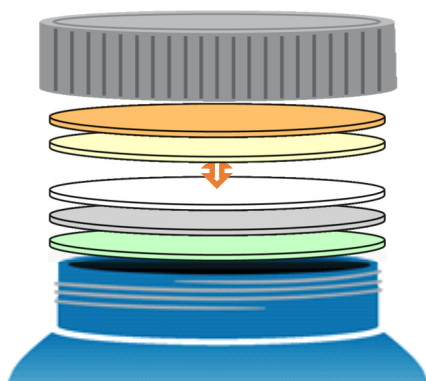
		SI (µm)	US (Mils)
White Lined Pulp Wax		889,0	35.0
White Paper		25,4	1.0
Aluminum Foil		71,1	2.8
Heat Seal		8,9	0.35
		38,1-76,2	1.5-3.0
Thickness Tolerance		± 10%	± 10%
Minimum Width		25,4 mm	1.0 in
Width Tolerance		± 1,6 mm	± 0.0625 in

#### Properties

Oxygen Transmission (O <sub>2</sub> TR)	Essentially Zero
Water Vapor Transmission (WVTR)	Essentially Zero

#### Regulatory Compliance

FDA Compliance	21 CFR 178.3710 Petroleum wax. 21 CFR 177.1350 Ethylene-vinyl acetate copolymers. 21 CFR 177.1210 Closures with sealing gaskets for food containers. 21 CFR 176.180 Components of paper and paperboard in contact with dry foods. 21 CFR 176.170 Components of paper and paperboard in contact with aqueous and fatty foods.
Drug Master File (DMF)	002518
Other Compliances	USFDA Food Allergen Guidelines   California Proposition 65 Labeling Requirements   Limitations of Heavy Metals in Packaging per CONEG & EU 94/62/EC, Article 11
Safety Data Sheet (SDS) Statement	Safety Data Sheets (SDS) are not required for articles as defined in 29 CFR 1910.1200, the OSHA Hazard Communication Standard (HazCom). This product is an article as defined by HazCom and is not considered to be, or to contain, a hazardous chemical based on evaluations made by our company.

Please note that construction does not reflect adhesive or resin bonding layers, if present.

Revision Number: 3  
Revised Date: 2018-05-29

**DISCLAIMER:** This information is believed to be accurate at the time of printing and is subject to change without notice. Providing this information does not convey any licenses under any patent rights or intellectual property rights of Tri-Seal or others. TRI-SEAL MAKES NO WARRANTY, EXPRESS OR IMPLIED, WITH RESPECT TO THIS INFORMATION AND DISCLAIMS ALL LIABILITY FROM RELIANCE ON IT. Tri-Seal's only warranties for this product are those written warranties as may be agreed to by Tri-Seal and its customers. TRI-SEAL SPECIFICALLY DISCLAIMS ALL OTHER WARRANTIES, EXPRESS OR IMPLIED, WITH RESPECT TO THE PRODUCT, INCLUDING, BUT NOT LIMITED TO, WARRANTIES OF MERCHANTABILITY AND FITNESS FOR PARTICULAR PURPOSE.

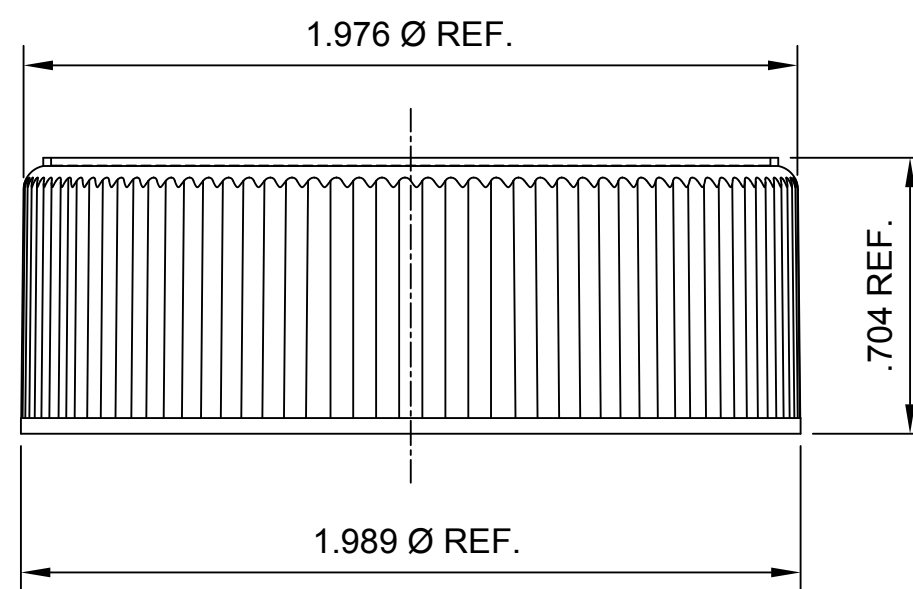
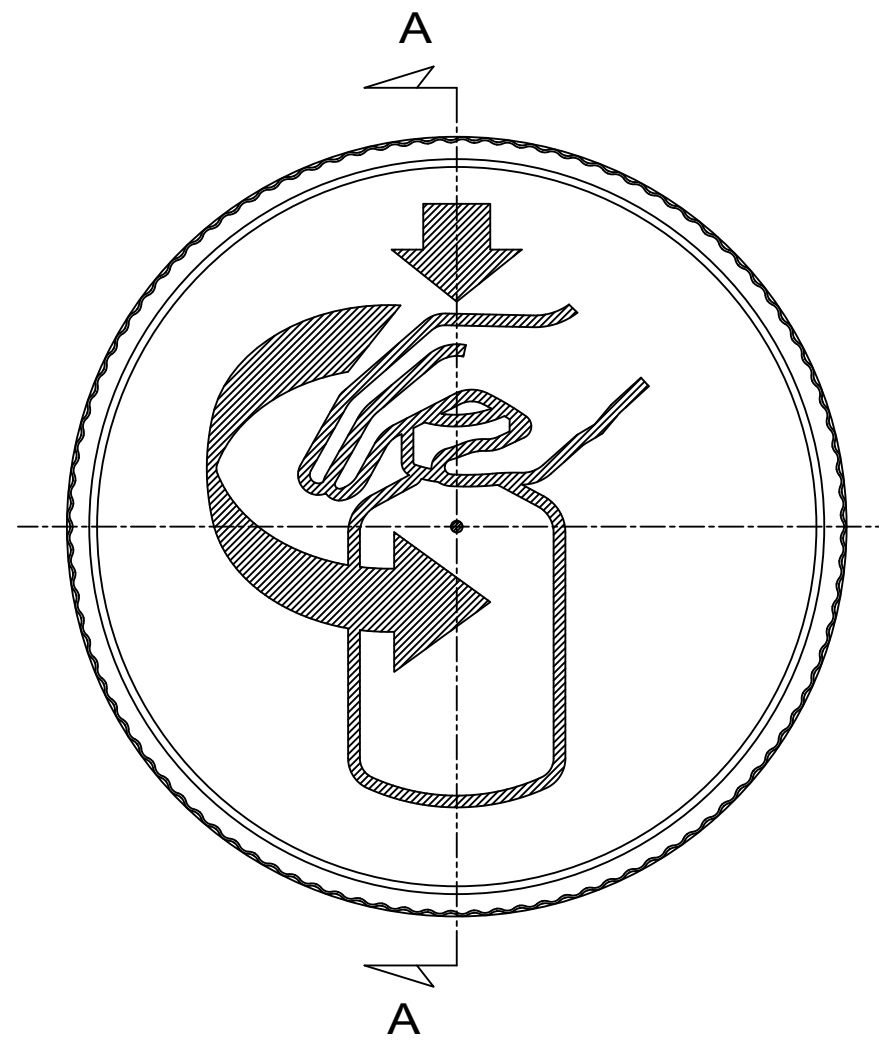

REFER TO GPI-400 & GPI-920 FINISHES - (6) TPI.  
 EITHER MAX. BEAD Ø OF BOTTLE = 1.839  
 OR MIN. "H" DIM. OF BOTTLE = .495

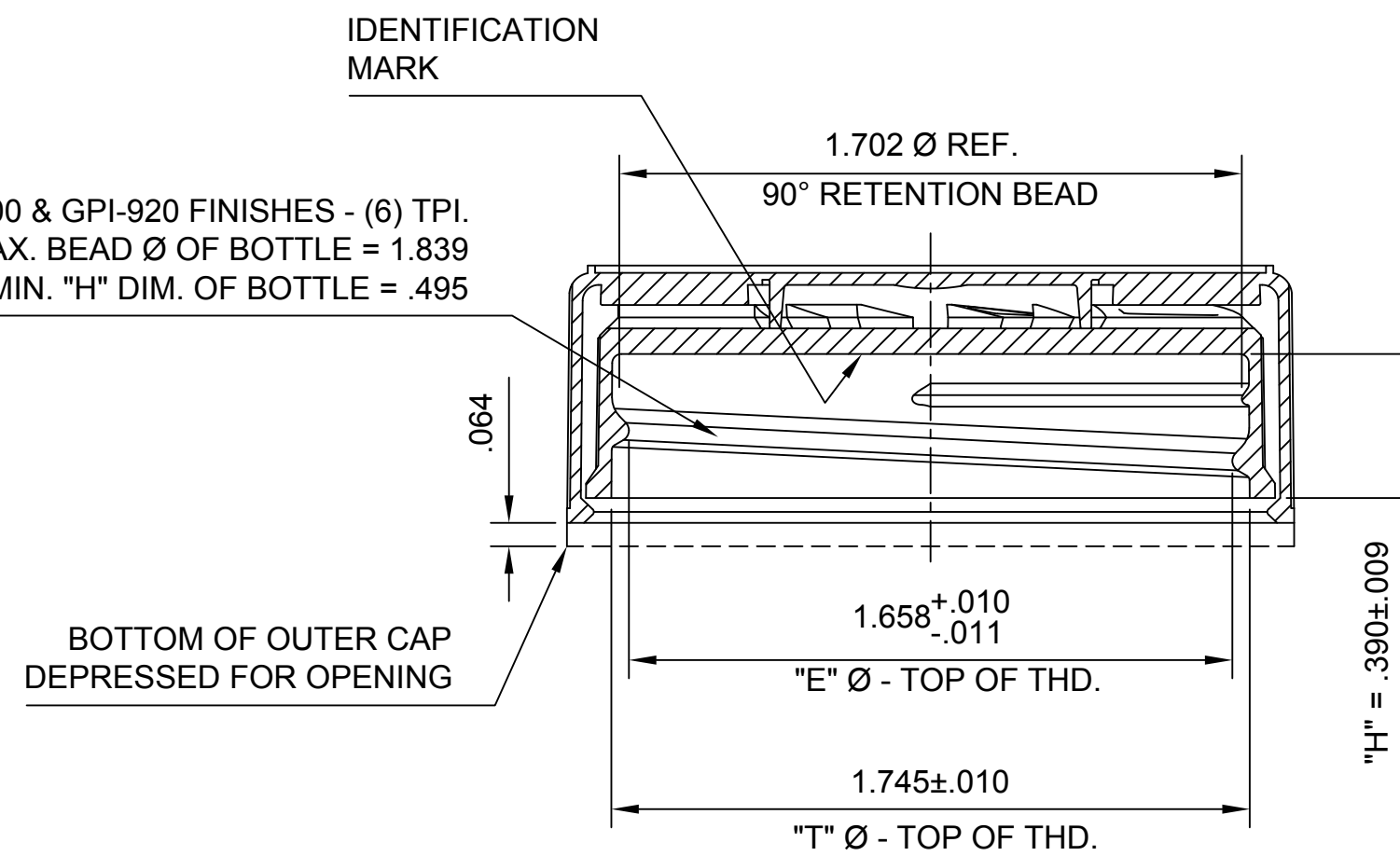

**SECTION A-A**

(XXX)		(XXX)	
REFERENCE DIMENSIONS ARE NOT INSPECTED AND NO TOLERANCE APPLIED		INSPECTION DIMENSIONS ARE VERIFIED WITH TOLERANCE	
THIS DRAWING IS NOT A CONTROLLED DOCUMENT IF PRINTED OR COPIED FROM THE APPROVED LOCATION			
JDE TOOL NUMBER: <b>CK45CRTPTASY</b>		DRAWING TYPE: <b>CUSTOMER</b>	
DESCRIPTION: 45MM - CR-III CLOSURE ASSEMBLY - 5427			
DRAWING NO: CP-040204-C		PROJECT NUMBER:	
CREATED BY: BCH	CREATION DATE: 08/12/02	DRAWING REVISION: A	SHEET 1 of 1
		SCALE: 2:1	SHEET SIZE C