

BOTTOM WITH INDEX LUG

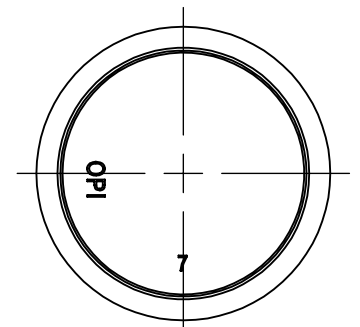

BOTTOM W/O INDEX LUG

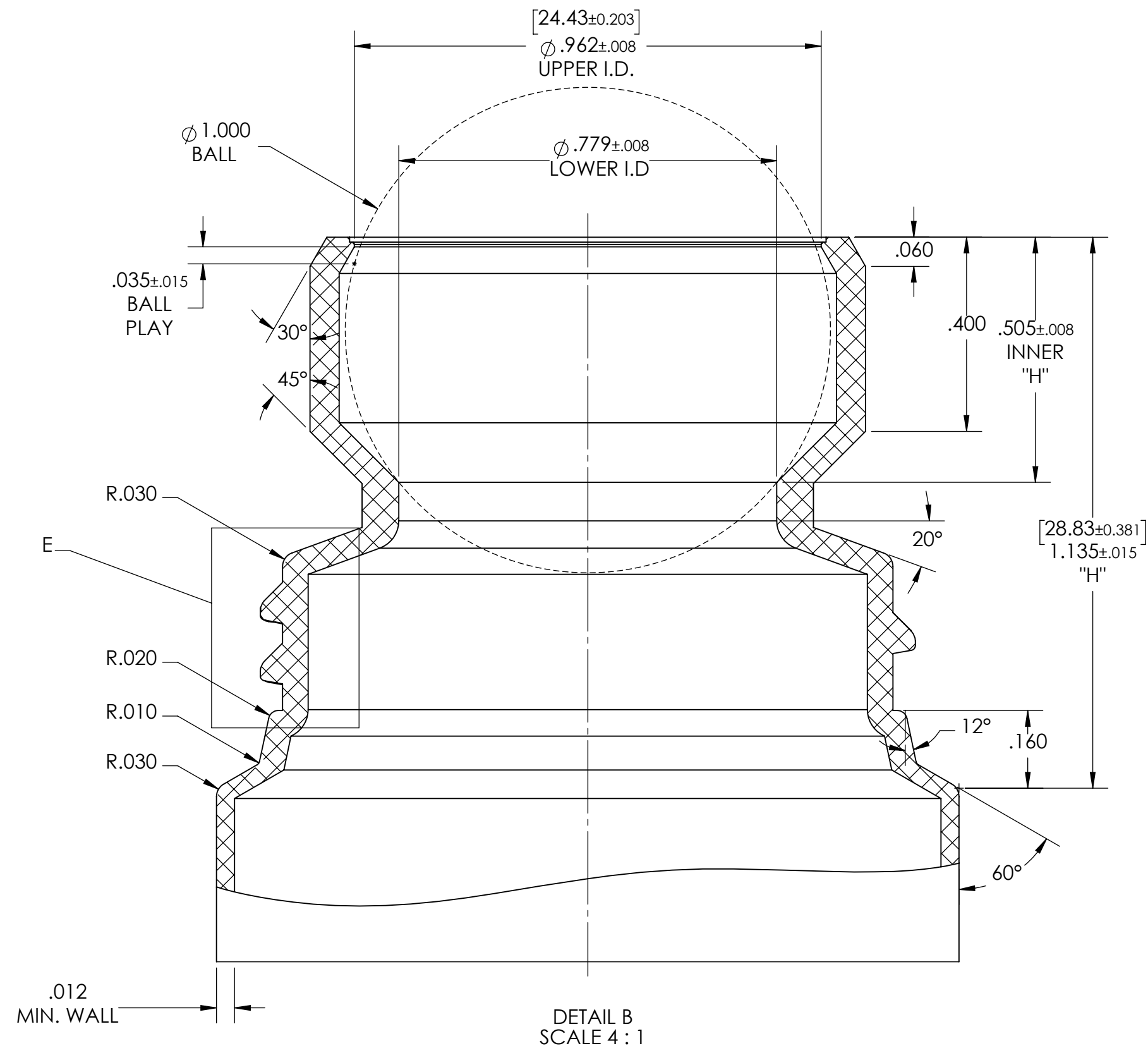

DETAIL B
SCALE 4 : 1

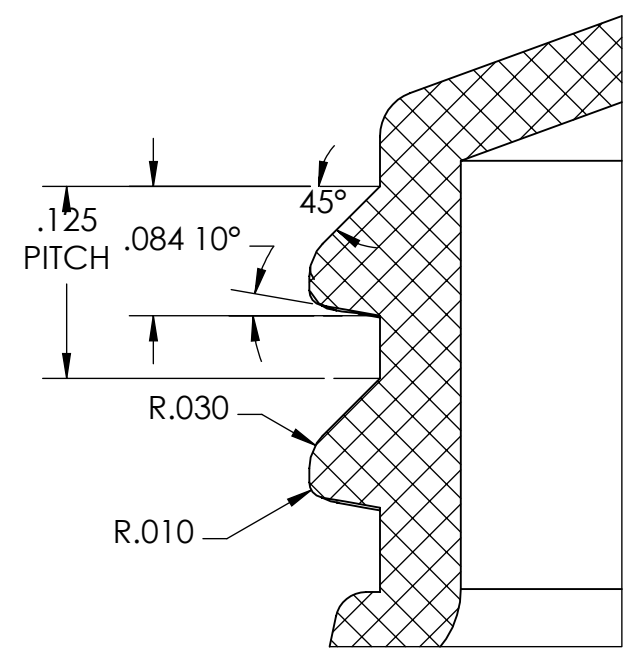

DETAIL E
SCALE 8 : 1

THREAD:
8 T.P.I.
1-1/2 FULL TURNS

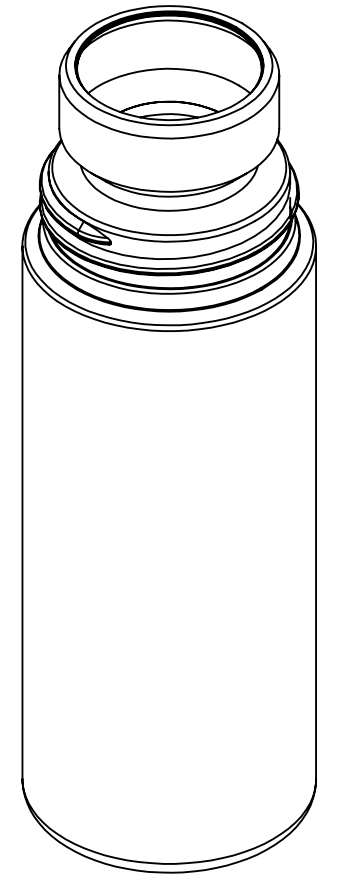

ISOMETRIC VIEW
ACTUAL SIZE



Part name: 3oz ROLL-ON BOTTLE	
Project name: 3oz ROLL-ON PACKAGE	
Material: HDPE	
Weight: 14.7 ±1.0 GR.	Over Flow Capacity: 110.0 ± 2.5CC
Designed by: BILL VOAG	
Approved by: B. KLOTZ	

CONFIDENTIAL PROPERTY
The reproduction, use, or disclosure, in whole or in part, of the design, or details contained herein is prohibited without prior written consent of Orange Products, Inc.

All dimensions in inches. General tolerances according to DIN 16901.

<input checked="" type="checkbox"/> INF Issued for Information	<input type="checkbox"/> IFA Issued for Approval	<input type="checkbox"/> IFC Issued for Construction	<input type="checkbox"/> IFP Issued for Production
---	---	---	---

Scale	Size	Drawing number	Rev.	Date:
1:1	C			