

NECK DETAIL
 SCALE 5
 REF. NECK FINISH: SP400-L89
 1 TURN
 PITCH: 5.08 [0.200], 5 TPI
 CUTTER DIA.: 12.7 [0.500]

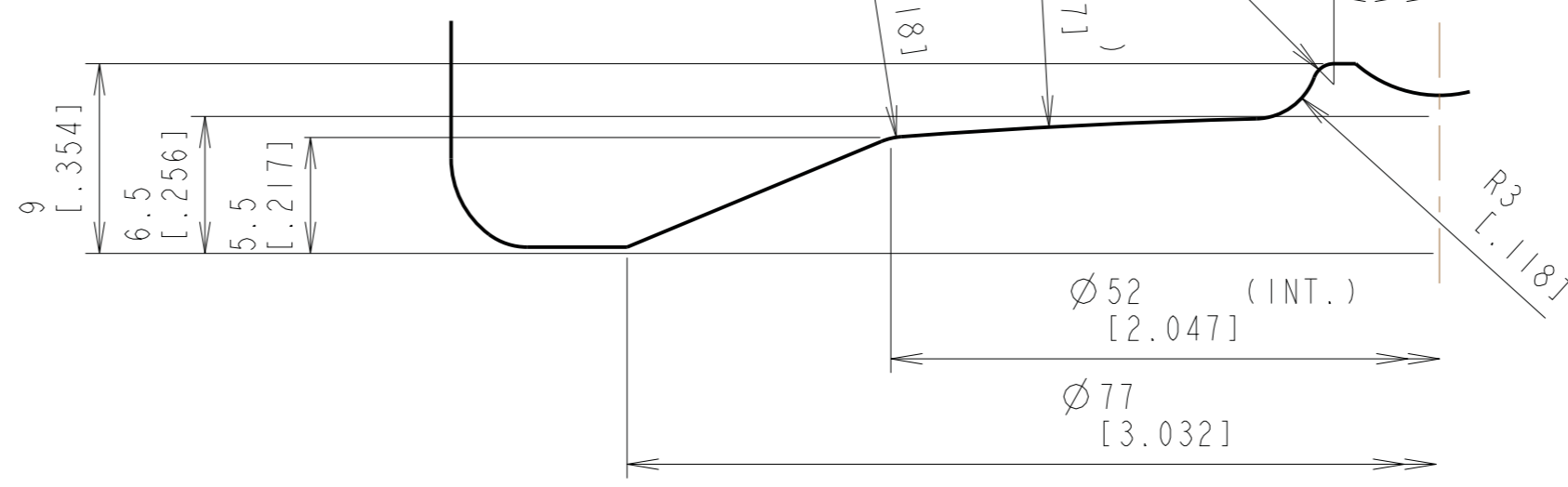

NOTES
 1. OVERFLOW CAPACITY 660 ± 8 mL
 2. WEIGHT 39 ± 1 g

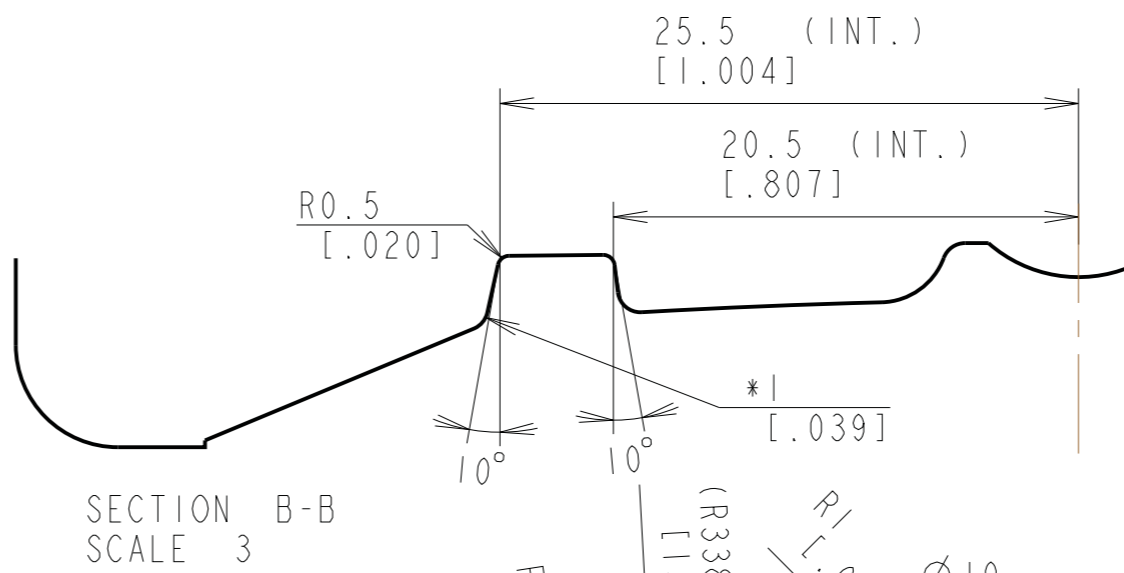
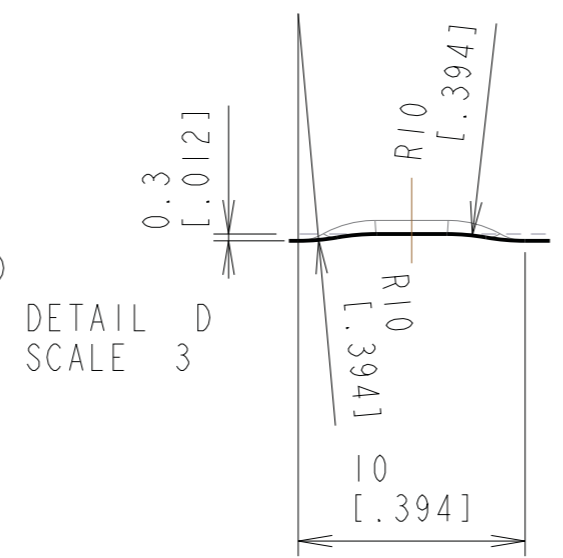
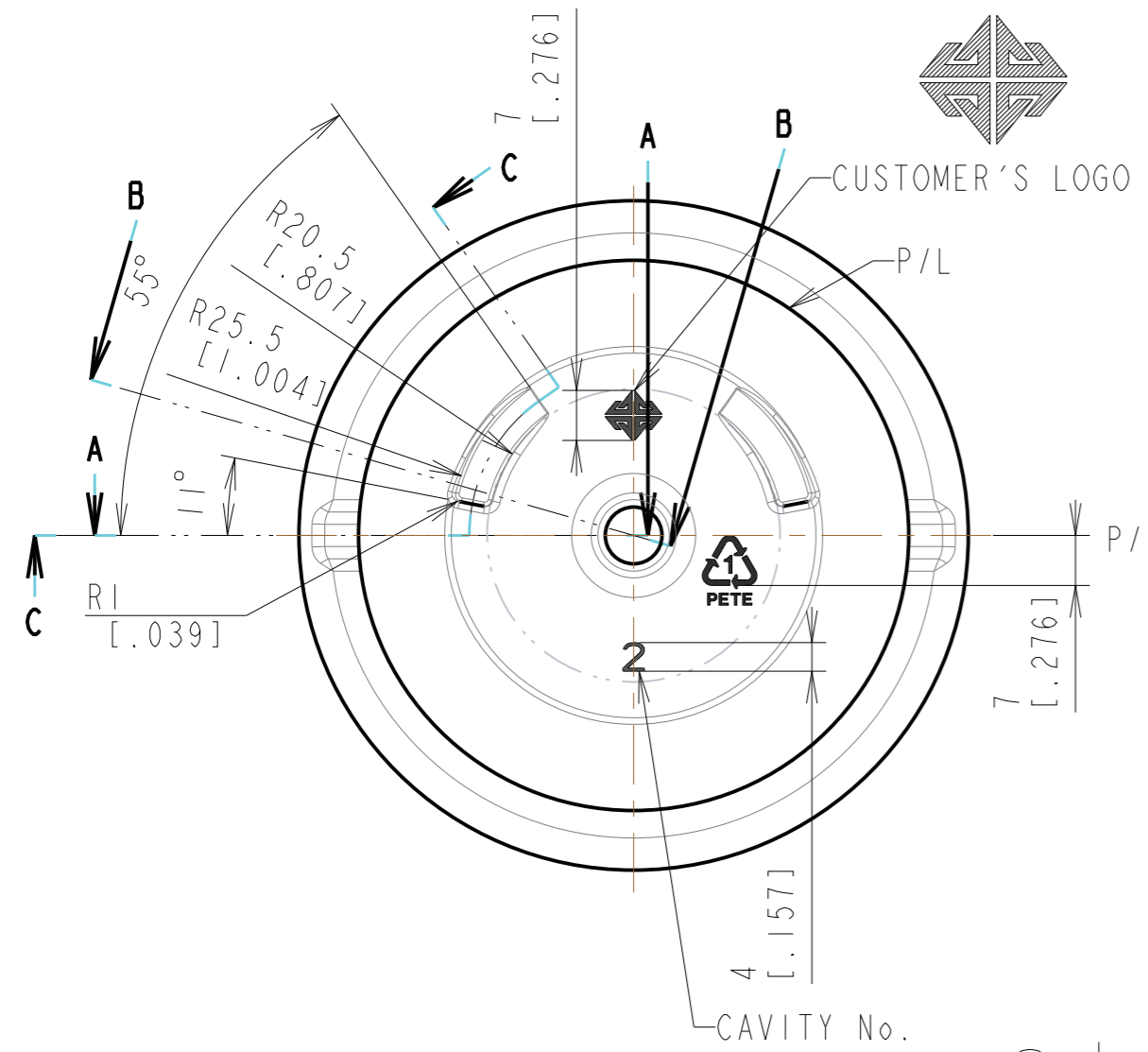
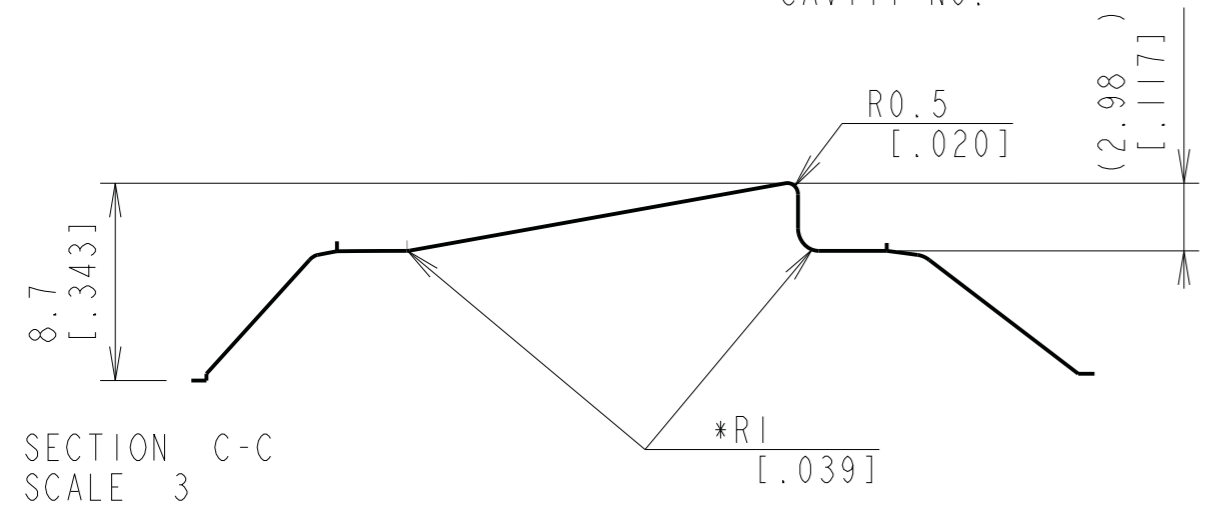

UI	R3 (0.3)	U2	DD (ddR)	D	0
N	9.46 (13.97 [0.550])	S	290 : 50.8	P	85.4

REV.	DATE	REVISIONS	BY
A2		CUSTOMER ZENITH GLOBAL	
MODEL	ASB-70DPH V4 SP	O'TY	DWG NO. 43-3128-00U
NAME	19oz JAR SP400-L89	SCALE	1/1 (3/1, 5/1)
REFERENCE NOTE	DR'N	CK'D	APPR.
	TB	SS	DATE AUG. 12. '21

