

REV	DATE	BY	REVISION
A	102715	ES	REDRAWN FROM DWG 82928RDOPD1.
B	012216	ES	ADDED 'I' DIM.
C	081518	ES	ADDED MIN. WALL LOCATION & NOTE 5.

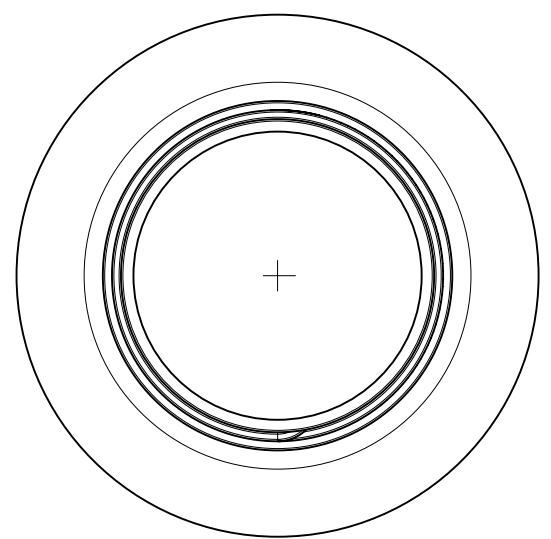

SCALE 0.750

APPROX. 300 ml
FILL LEVEL

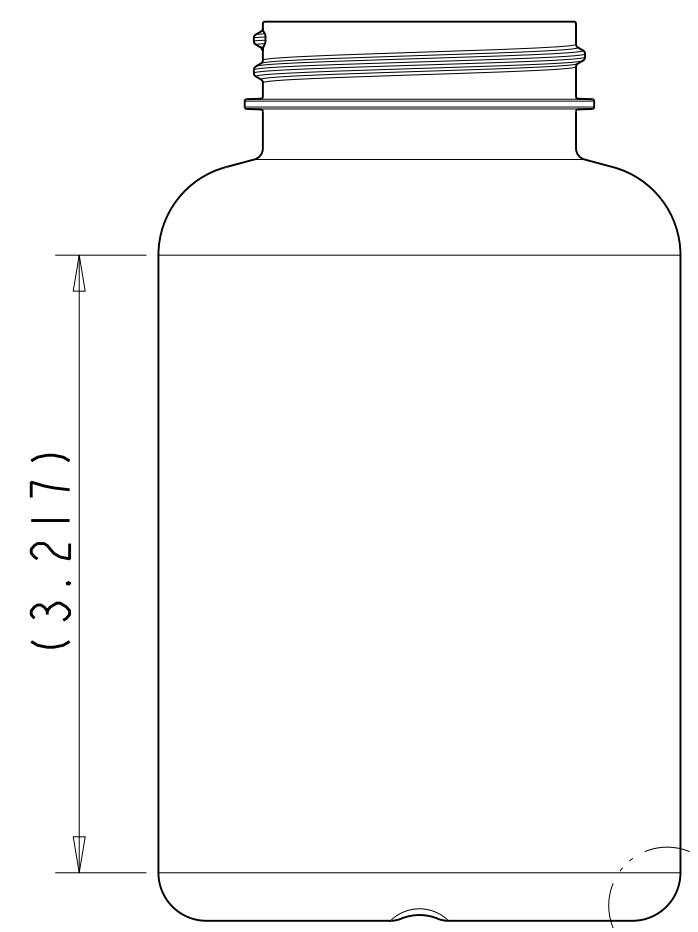
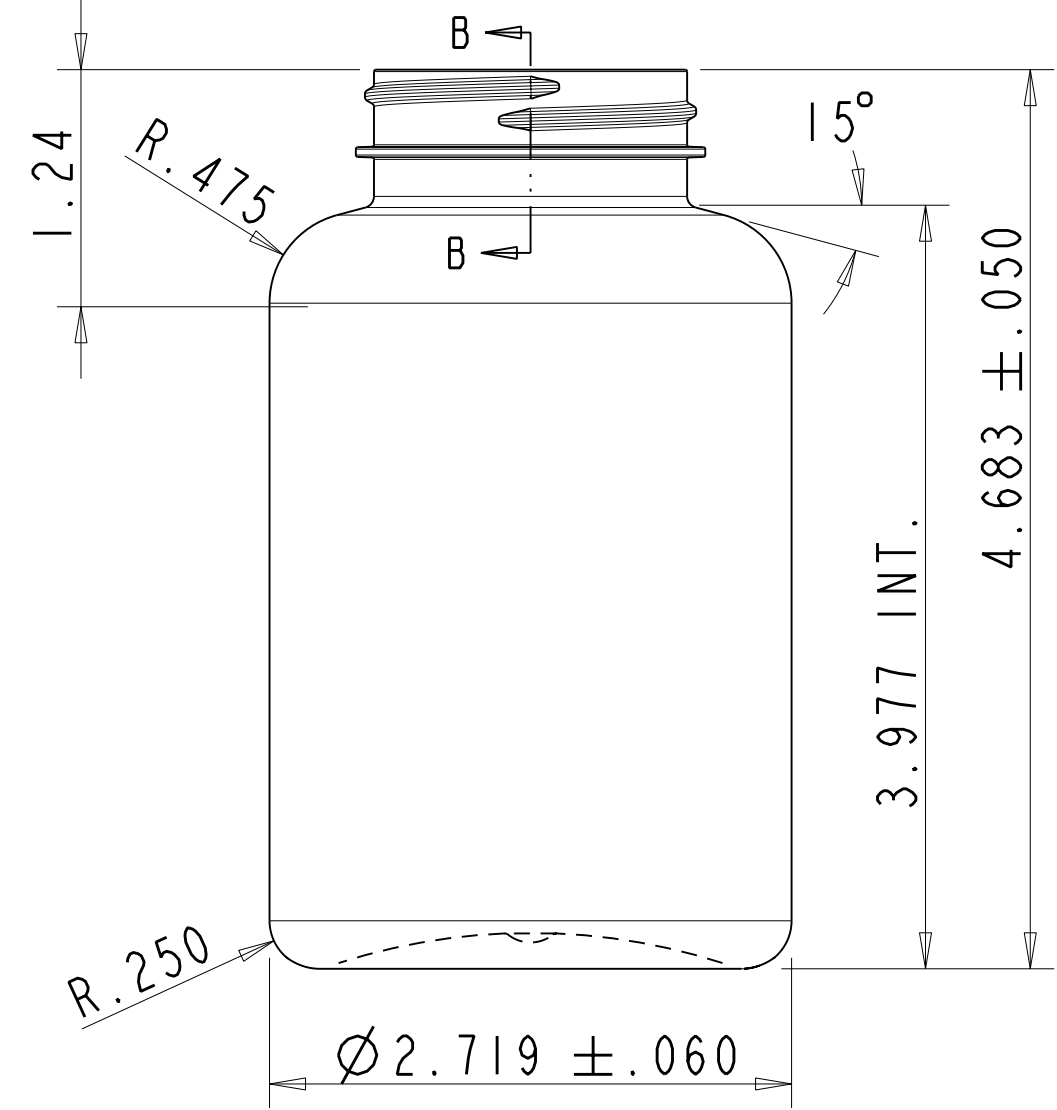

Ø .012" MIN. WALL

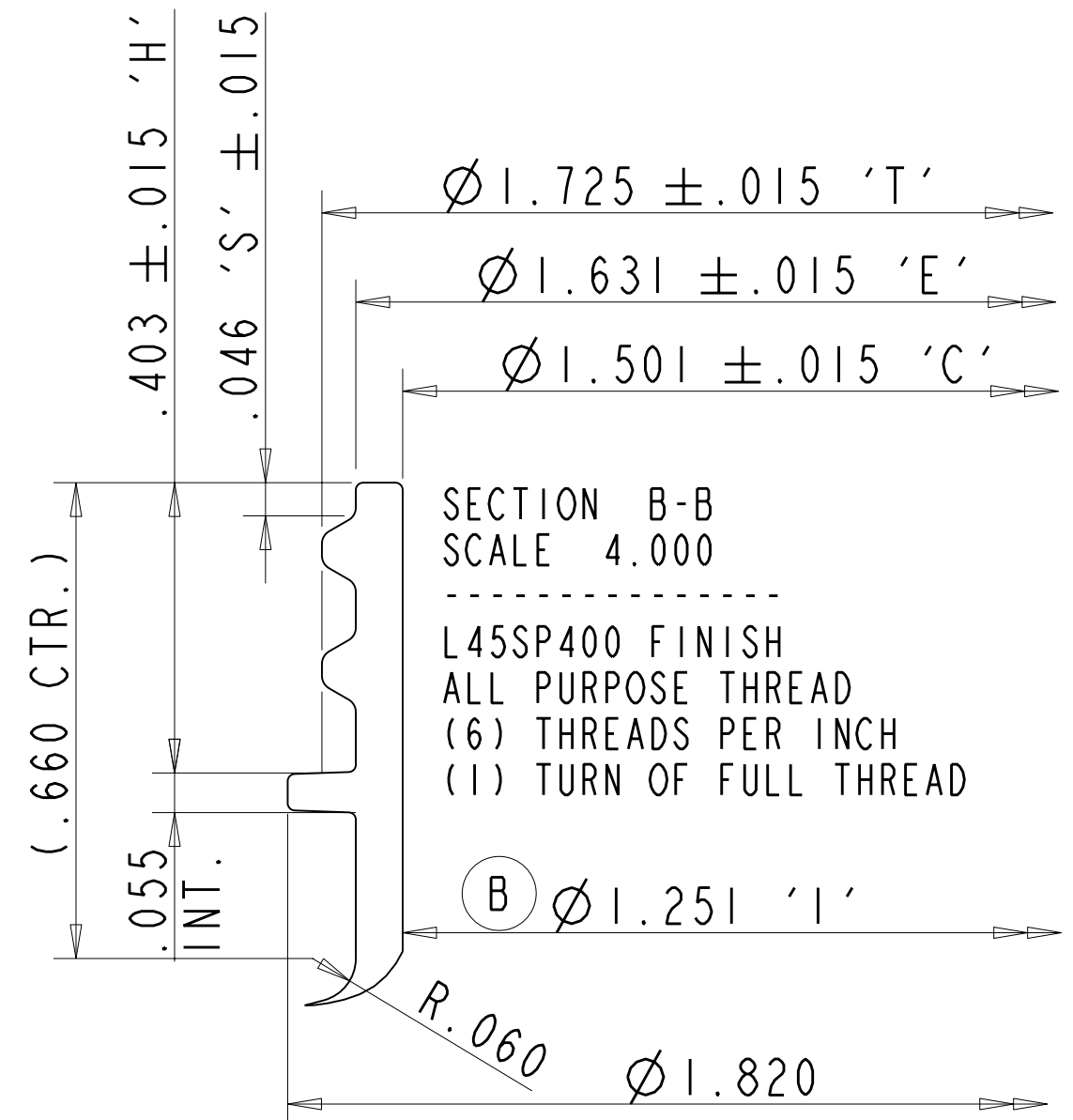

SECTION A-A
SCALE 2.000

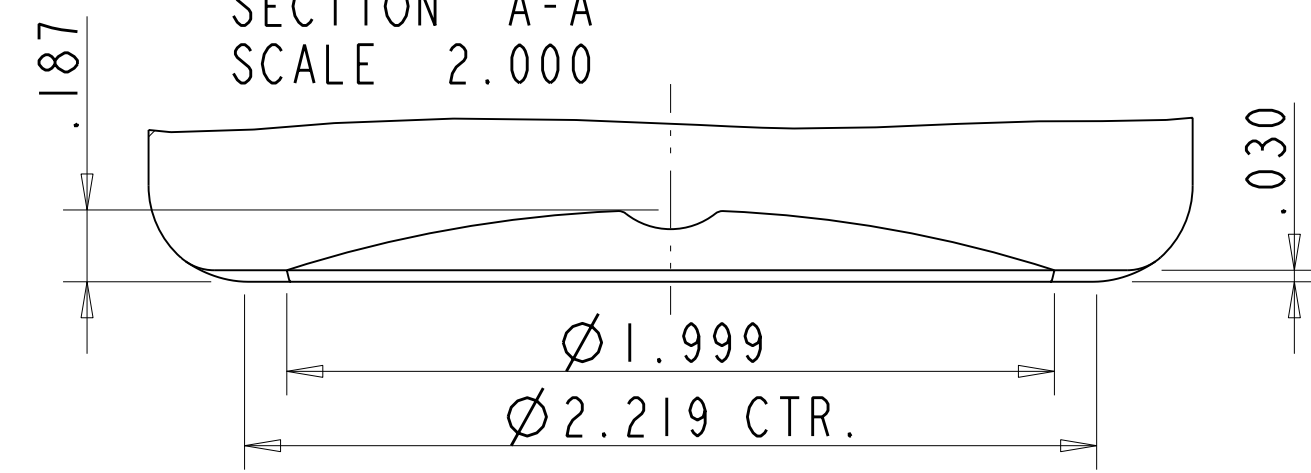

NOTES:

- 1 - MOLD NO. - 400120
- 2 - MAX. VARIATION IN AVERAGE DIAMETER BETWEEN TOP AND BOTTOM NOT TO EXCEED .010
- 3 - ALL DIMENSIONS APPLY AS MOLDED
- 4 - MAXIMUM OUT OF ROUNDNESS ON BODY OF CONTAINER NOT TO EXCEED .015.
- 5 - .012" MIN. WALL THICKNESS.

RECYCLING CODE

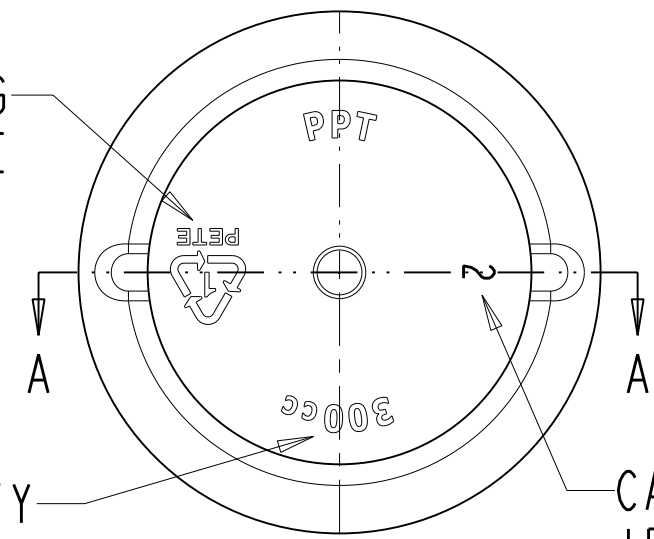

CAPACITY DESIGNATION

CAVITY IDENTIFICATION

RESTRICTED, CONFIDENTIAL DOCUMENT

THIS DOCUMENT AND THE INFORMATION THEREON IS THE SOLE AND EXCLUSIVE PROPERTY OF PERFORMANCE PLASTIC TECHNOLOGIES AND/OR ITS DESIGNATED DISTRIBUTOR ABOVE. IT IS BEING ENTRUSTED TO RECIPIENT FOR A SPECIFIC LIMITED PURPOSE AND MAY BE USED ONLY FOR SUCH PURPOSE. BY ACCEPTING THIS DOCUMENT, THE RECIPIENT AGREES THAT HE WILL ENSURE THAT THE DOCUMENT AND ALL INFORMATION THEREON: (1) WILL BE MAINTAINED IN STRICTEST CONFIDENCE; (2) WILL NOT BE REPRODUCED, IN WHOLE OR IN PART, IN ANY MANNER WHATSOEVER WITHOUT THE EXPRESS WRITTEN APPROVAL OF PPT; (3) WILL NOT BE DISCLOSED DIRECTLY OR INDIRECTLY, IN ANY MANNER OR FORM, TO ANY THIRD PARTY WITHOUT THE EXPRESS WRITTEN APPROVAL OF PPT AND; (4) WILL BE PROMPTLY AND VOLUNTARILY RETURNED, WITH ANY AND ALL COPIES, TO PPT WHEN IT HAS SERVED THE PURPOSE INTENDED BY PPT, OR AT THE REQUEST OF PPT.



300 cc CT ROUND WIDE MOUTH PACKER
L45SP400 FINISH

42.54 SQUARE INCHES	10.85 SQUARE INCHES	38 ± 2	PET	359.6 ± 9 cc (12.16 ± .30 fl oz)
SURFACE AREA BELOW BASE OF NECK	AREA AT PART LINE BELOW BASE OF NECK	GRAMS	MAT'L.	OVERFLOW CAPACITY

FILE NAME: XXXX_300cc-STR-SIDE (15-086-01-C)	SIZE C	DRAWN BY: ES	DWG NO. 3201-0203-C
SCALE: 1,4:1	DATE: 10-07-2015	SHEET	1 OF 1