

DETAIL B
SCALE 20 : 1
(82 EQUALLY SPACED KNURLS)

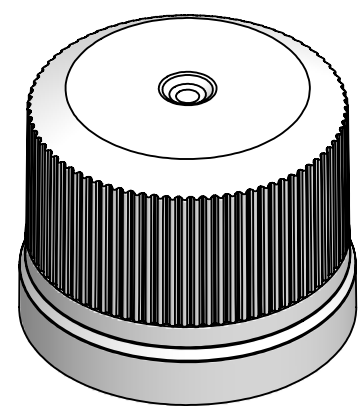
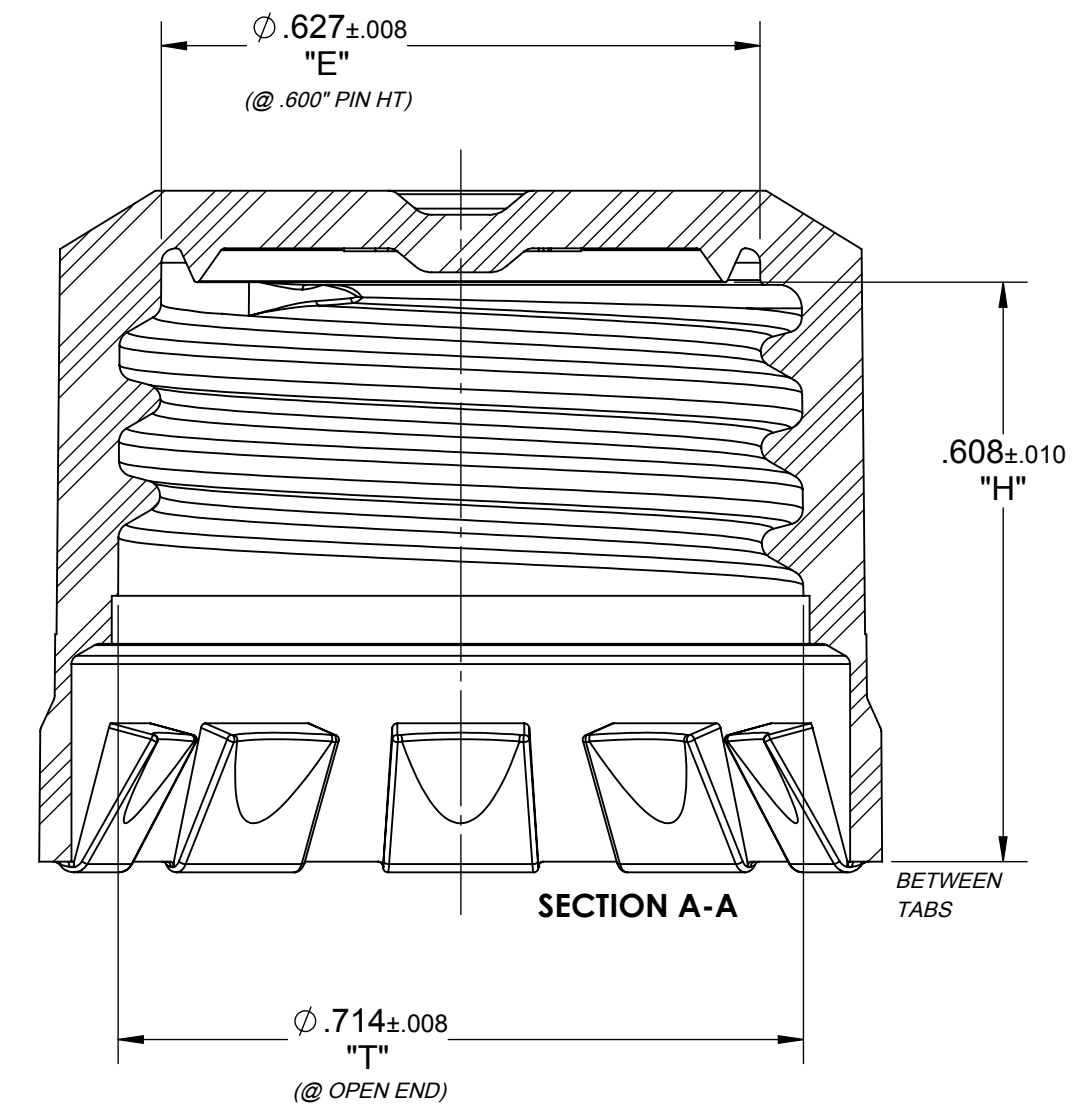
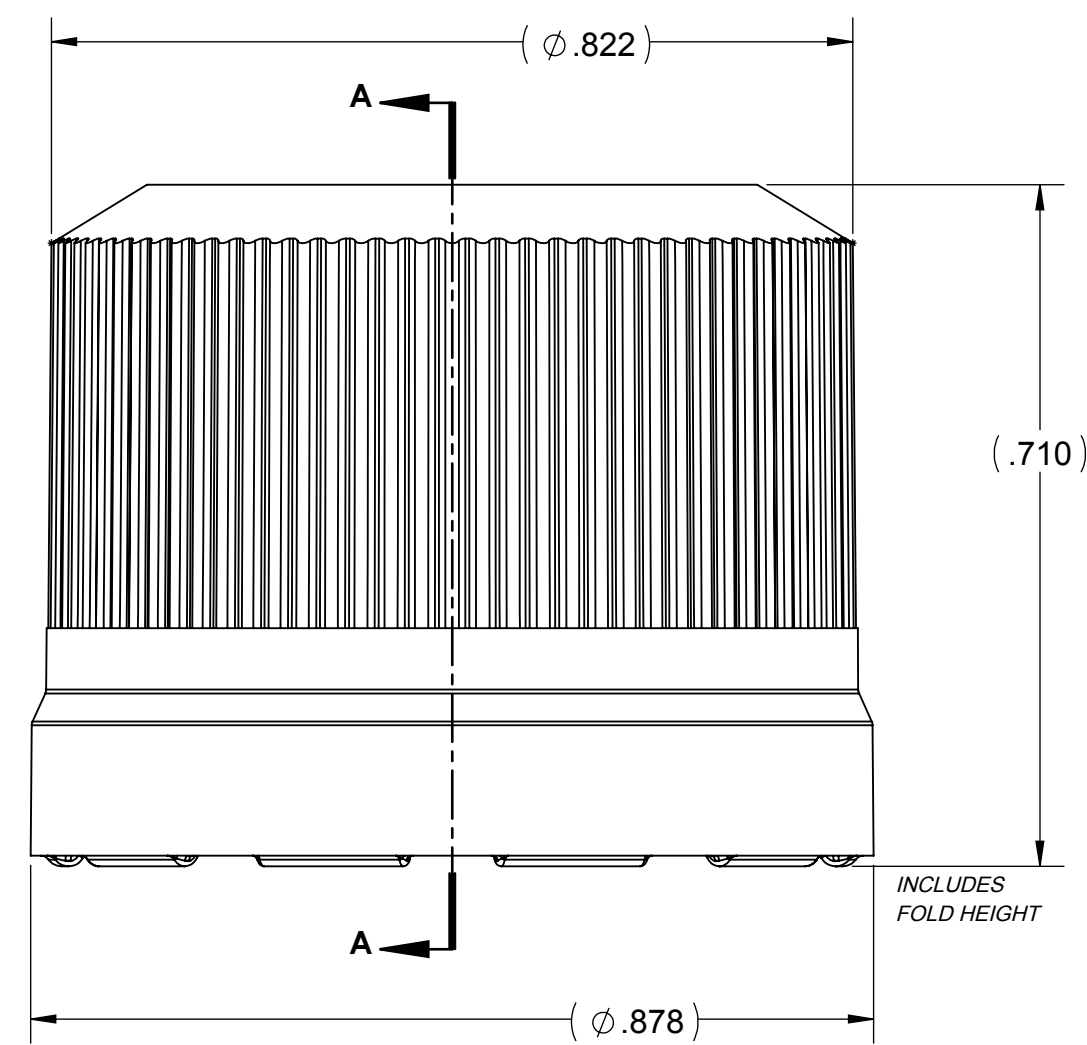

SCALE 2 : 1

THREAD DEVELOPMENT

- RIGHT HAND THREAD
- 10 TPI (.100 PITCH)
- TANGENTIAL THREAD START

FINISH COMPATIBILITY

- GLASS (SK-1332)
- PLASTIC (84126-C)

NOTES

- DO NOT SCALE DRAWING
- DRAWING SUPERSEDES CP-060432-C

REFERENCE DIMENSIONS ARE NOT INSPECTED AND NO TOLERANCE APPLIED INSPECTION DIMENSIONS ARE VERIFIED WITH TOLERANCE

THIS DRAWING IS NOT A CONTROLLED DOCUMENT IF PRINTED OR COPIED FROM THE APPROVED LOCATION

TOLERANCE UNLESS SPECIFIED	xxx +/- .010	<p>101 OAKLEY STREET EVANSVILLE, INDIANA 47706 TEL. (812) 424-2904</p>	CONFIDENTIAL				
	xx +/- .015		SIZE AND STYLE: CK18LLTENK	DRAWING TYPE: CUSTOMER			
	x +/- .025		DESCRIPTION: 18mm TE-III LINERLESS CLOSURE				
	Fractional +/- 1/32"		DRAWING NO: CP-130844-PRT01	PROJECT NUMBER: 1300069			
Angles +/- 1/2°	LAST MODIFIED BY AND DATE: mrussell - 10/1/2018 4:33:30 PM	CREATED BY: E. SWEENEY	CREATION DATE: 2015-12-29	DRAWING REVISION: C	SHEET: 1 of 1	SCALE: 5:1	SHEET SIZE: C