

For more information and technical assistance contact:

Chevron Phillips Chemical Company LP
P.O. Box 4910
The Woodlands, TX 77387-4910
800.231.1212



PREMIUM EXTRUSION AND RIGID PACKAGING RESINS

Marlex® HHM 5502BN

HIGH DENSITY POLYETHYLENE

This high molecular weight, hexene copolymer is tailored for lightweight blow molded containers that:

- Require excellent stiffness
- Require exceptional processability
- Are durable and recyclable for sustainability

Typical blow molded applications for HHM 5502BN include:

- Ice chests and coolers
- Household and industrial chemical containers
- Food packaging
- Pharmaceuticals

This resin meets these specifications:

- ASTM D4976 - PE 235
- FDA 21 CFR 177.1520(c) 3.2a, use conditions B through H per 21 CFR 176.170(c)
- Listed in the Drug Master File

NOMINAL PHYSICAL PROPERTIES ⁽¹⁾	English	SI	Method
Density	---	0.955 g/cm ³	ASTM D1505
Melt Index, 190/2.16	---	0.35 g/10 min	ASTM D1238
Tensile Strength at Yield, 2 in/min, Type IV bar	4,000 psi	27 MPa	ASTM D638
Elongation at Break, 2 in/min, Type IV bar	600%	600%	ASTM D638
Flexural Modulus, Tangent - 16:1 span:depth, 0.5 in/min	200,000 psi	1,370 MPa	ASTM D790
ESCR, Condition B (100% Igepal), F ₅₀	35 h	35 h	ASTM D1693
Brittleness Temperature, Type A, Type I specimen	<-103°F	<-75°C	ASTM D746

1. The nominal properties reported herein are typical of the product, but do not reflect normal testing variance and therefore should not be used for specification purposes. Values are rounded. The physical properties were determined on compression molded specimens that were prepared in accordance with Procedure C of ASTM D4703, Annex A1.

MSDS #240370

Revision Date May, 2007

Another quality product from



Before using this product, the user is advised and cautioned to make its own determination and assessment of the safety and suitability of the product for the specific use in question and is further advised against relying on the information contained herein as it may relate to any specific use or application. It is the ultimate responsibility of the user to ensure that the product is suited and the information is applicable to the user's specific application. Chevron Phillips Chemical Company LP does not make, and expressly disclaims, all warranties, including warranties of merchantability or fitness for a particular purpose, regardless of whether oral or written, express or implied, or allegedly arising from any usage of any trade or from any course of dealing in connection with the use of the information contained herein or the product itself. The user expressly assumes all risk and liability, whether based in contract, tort or otherwise, in connection with the use of the information contained herein or the product itself. Further, information contained herein is given without reference to any intellectual property issues, as well as federal, state or local laws which may be encountered in the use thereof. Such questions should be investigated by the user.



11585 White PE MB

Product Information

Physical Properties

Carrier Resin

Type	LD	PE
Melt Index	8	(nominal) ASTM D1238, 190 / 2 .16
Density	.92	gm/cc

Concentrate

Specific Gravity	1.73	(nominal)
Melt Index	3-7	(nominal) ASTM D1238, 190 / 2.16
Pigment	60%	(nominal)

Regulatory Status

Food Contact

This material is composed of ingredients that are cleared by the U.S. Federal Food and Drug Administration (FDA) for safe use in *Polyethylene* and may be used in food contact applications under conditions of use E through G in 21 CFR, § 176.70(c).

CONEG

This product complies with all applicable CONEG heavy metal restrictions.

Comments

The amount of masterbatch depends on the performance requirements of the final application. This product is primarily designed for molding applications.

Date Printed: 10/26/2005

The information and recommendations contained in this document are based upon data collected by Ampacet and believed to be correct. However, no warranty of fitness for use or any other guarantees or warranty of any kind, express or implied, is made to the information contained herein, and Ampacet assumes no responsibility for the results of the use of products and processes described herein. No liability whatsoever shall attach to Ampacet for any infringement of the rights owned or controlled by a third party in intellectual, industrial or other property by reason of the application, processing or use of the aforementioned information or products by the buyer. This is an uncontrolled document.

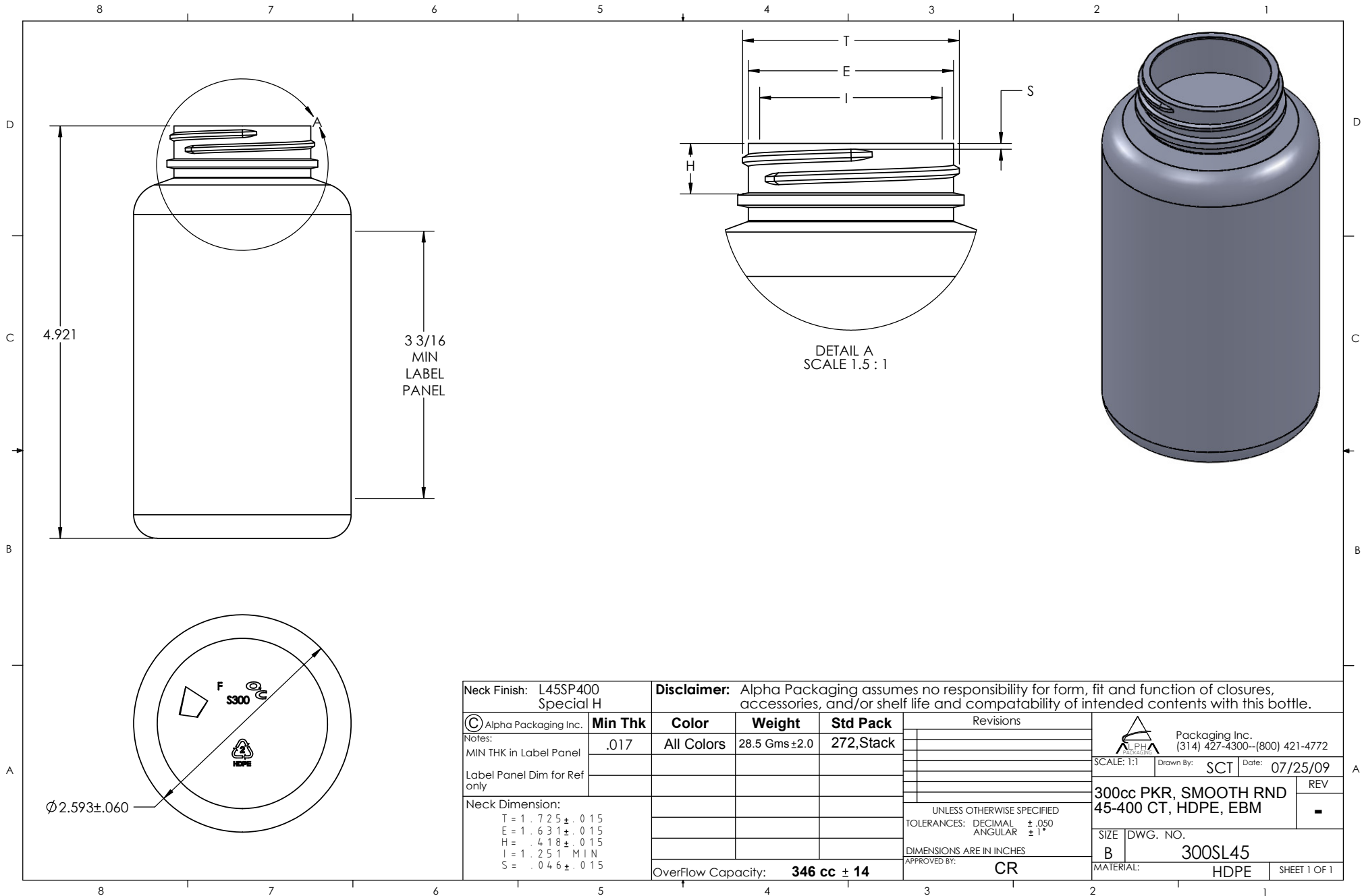

Neck Finish: L45SP400 Special H		Disclaimer: Alpha Packaging assumes no responsibility for form, fit and function of closures, accessories, and/or shelf life and compatibility of intended contents with this bottle.			
© Alpha Packaging Inc.	Min Thk	Color	Weight	Std Pack	Revisions
Notes: MIN THK in Label Panel	.017	All Colors	28.5 Gms ± 2.0	272, Stack	
Label Panel Dim for Ref only					
Neck Dimension: T = 1.725 ± .015 E = 1.631 ± .015 H = .418 ± .015 I = 1.251 MIN S = .046 ± .015				UNLESS OTHERWISE SPECIFIED TOLERANCES: DECIMAL ± .050 ANGULAR ± 1°	
Overflow Capacity: 346 cc ± 14				APPROVED BY: CR	
Alpha Packaging Inc. (314) 427-4300--(800) 421-4772		SCALE: 1:1 Drawn By: SCT Date: 07/25/09			
		300cc PKR, SMOOTH RND 45-400 CT, HDPE, EBM			REV
		SIZE DWG. NO. B 300SL45			
		MATERIAL: HDPE			SHEET 1 OF 1