

2

1

B

B

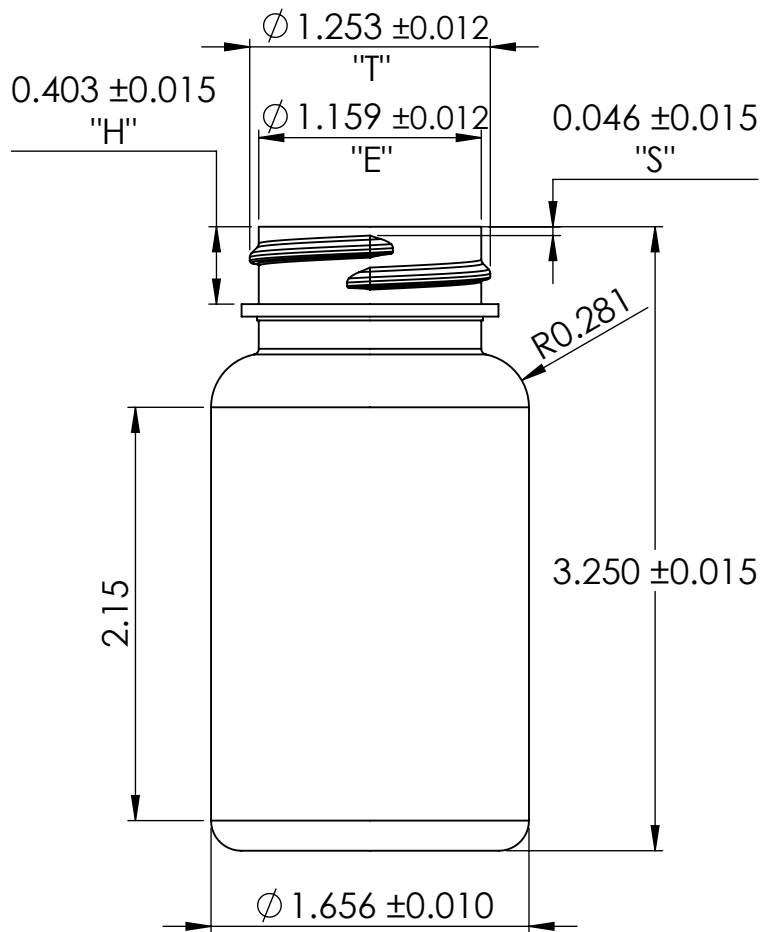

SPECIFICATION NECK FINISH 33SP400		
KEY	MAX	MIN
T	1.265	1.241
E	1.171	1.147
H	0.418	0.388
S	0.061	0.031
I	1.048	1.088

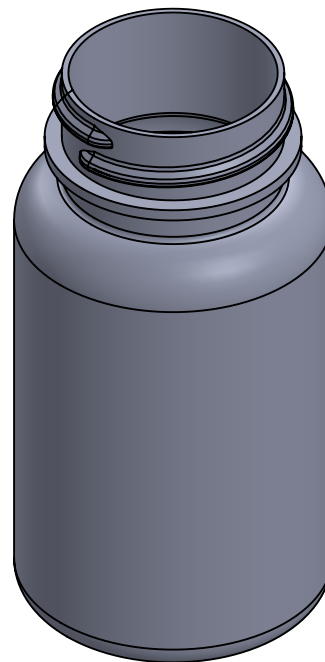

A

A

**PROPRIETARY AND CONFIDENTIAL**

THIS DOCUMENT IS THE EXCLUSIVE PROPERTY OF TIM PLASTICS, INC. THE INFORMATION CONTAINED HEREIN, AND ANY MODEL CONTAINER OR OTHER ARTICLE RECEIVED, IS PROPRIETARY AND CONFIDENTIAL AND MUST ONLY BE USED FOR THE PURPOSE FOR WHICH IT WAS DISCLOSED. THE HOLDER WILL NOT DISCLOSE TO A THIRD PARTY. UPON COMPLETION OF USE OR BY REQUEST, THIS MATERIAL IS TO BE RETURNED TO TIM PLASTICS, INC. THIS DOCUMENT IS NO LONGER A CONTROLLED DOCUMENT WITHIN TIM PLASTICS, INC. DO NOT ASSUME THAT THIS DRAWING IS CURRENT.

2

Rev.	Description	By	Date	ECR
A	Original Release	AS	6/26/2007	N/A
B	Update format, 3D Model	SM	5/11/2018	N/A

**Notes/Comments:**

1. Dimensions are nominal (millimeters/inches).
2. This drawing represents the bottle 72 hours after time of manufacture. (Storage at nominal conditions)
3. The dimensional tolerances applied to the Overall Height of the container are to be applied to all height dimensions.
4. The dimensional tolerances applied to the major diameter or width of the container are to be applied to all diameter, width and thickness dimensions.
5. The actual weight will vary based on the actual production weight of the preforms
6. Fill levels are based on room temperature water
7. Tim Plastics, Inc. assumes no responsibility for fit, function or form of closures, accessories and/or shelf life and compatability of intended contents with this bottle.
8. The customer is responsible to determine the suitability of the intended use of this product and to keep it in a suitable environment (cool and dry) during transportation, storage and handling.

**CONFIDENTIAL**

**Volume & Weight Information**

**Capacity Specification**

Fill Line Capacity (Approximate):	75 ml	Overflow Capacity:	92.0 ± 2.0 ml	Process/Preform:	ISBM
Material:	PETE	Container Target Weight:	12.5 ± 1.5 gm	Neck Finish:	33SP400

**Drawing Information**

Date:	5/11/2018	Drawn By:	SM
Scale:	SCALE: 1:1	Checked By:	AS

**75cc Round Bottle**

Drawing Type:	Product Drawing	
Drawing Number:	A 3001075	Rev. B
		<b>Tim Plastics, Inc.</b> 97 N. Leslie Rd. North East, MD 21901

1