

.046±.015  
"S" DIM.

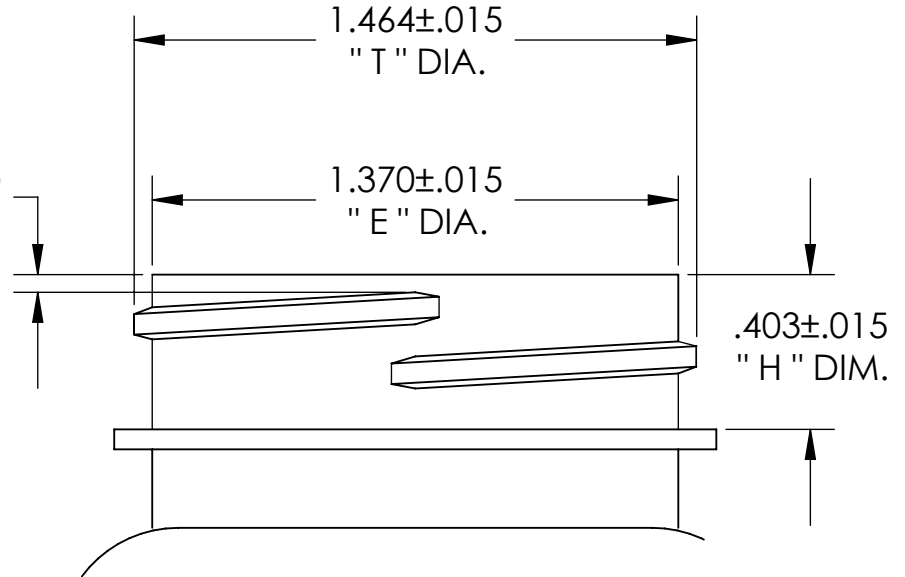

DETAIL A  
SCALE 2 : 1

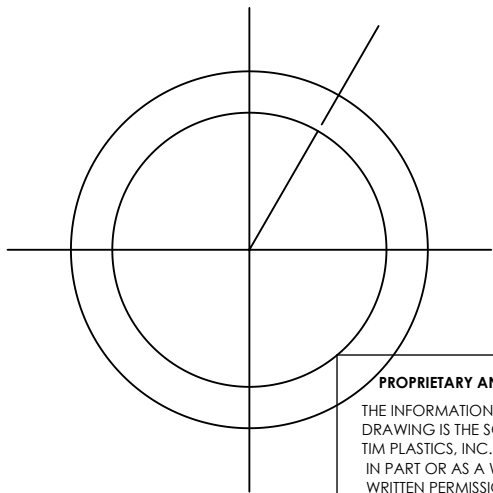

Rev. B Minimum wall thickness added 12-05-13

**PROPRIETARY AND CONFIDENTIAL**  
THE INFORMATION CONTAINED IN THIS DRAWING IS THE SOLE PROPERTY OF TIM PLASTICS, INC. ANY REPRODUCTION IN PART OR AS A WHOLE WITHOUT THE WRITTEN PERMISSION OF TIM PLASTICS, INC. IS PROHIBITED.

UNLESS OTHERWISE SPECIFIED:		NAME	DATE	<b>TIM PLASTICS, INC.</b>		
DIMENSIONS ARE IN INCHES TOLERANCES: FRACTIONAL ± 1/16 ANGULAR: MACH ± 1° BEND ± 1° TWO PLACE DECIMAL ±.05 THREE PLACE DECIMAL ±.005 Minimum wall thickness 0.012		DRAWN	AS 8-06-09			TITLE:
		CHECKED	NP 8-06-09	<b>100cc ROUND BOTTLE-H (38SP400)</b>		
		ENG APPR.	AMIT SHAH 8-06-09			
		MFG APPR.	TP 8-06-09	SIZE	DWG. NO.	REV
		Q.A.	JS 12-05-13	<b>A</b>	<b>3001101</b>	<b>B</b>
INTERPRET GEOMETRIC TOLERANCING PER:		COMMENTS:		SCALE: 1:1		SHEET 1 OF 1
MATERIAL		O'FLOW: 118.0±2.0cc				
<b>PET</b>		Weight: 18.0±2.0gms				
FINISH						
<b>38SP400</b>						
DO NOT SCALE DRAWING						