

# EASTLON PET CB-602 (CLEAR)

## PHYSICAL PROPERTY DATA SHEET

Product Name : EASTLON PET CB-602  
Chemical Name : Poly (Ethylene Terephthalate - Isophthalate)  
Formula :  $(\text{OCOC}_6\text{H}_4\text{COOCH}_2\text{CH}_2)_n$   
Manufacturer : FAR EASTERN NEW CENTURY CORPORATION  
33F No. 207 Sec 2 Tun Hwa S. RD Taipei Taiwan  
TEL: 886-2-27338000 FAX : 886-2-27368304  
Version : "FGE"4235

Property, Units	Test Method	Value
Density, g/cm <sup>3</sup>	ASTM-D-1505	1.40
Bulk Density, lb/ft <sup>3</sup> (kg/m <sup>3</sup> ) Poured Vibrated	ASTM-D-1895	49 (785) 54 (870)
Melt Density, @285°C, g/cm <sup>3</sup>	-	1.2
Molecular Number average (Mn)	-	28,000
Molecular Weight average (Mw)	-	42,000
Intrinsic viscosity *	ASTM-D-4603	0.80 ± 0.02
Crystallinity, %	-	> 45
Crystalline Peak Melting Point, °C	ASTM-D-3418	250 ± 5
Heat of Fusion, cal/g (j/kg)	DSC	14 (58 * 10 <sup>3</sup> )
Thermal Conductivity, Cal/cm°C . S(W/m.k)	ASTM-D-177	6.5*10 <sup>-4</sup> (0.27)
Acetaldehyde, ppm	Celanese-Method	< 1.0
Diethylene Glycol, % by wt.	-	1.3 ± 0.2
Pellets Weight, g/100 grains	-	1.5 ± 0.2

\* Eastlon PET CB-602 is a condensation polymer produced from pure terephthalic acid (PTA), isoterephthalic acid (IPA) and ethylene glycol (EG) using a continuous polymerization.

\* Packing : 1,100 or 1,050kgs in PP woven bag with PE interlining.  
20bags in one 20 feet container.

\* Properties reported here are typical of average lots.  
FENCC makes no representation that the material in any particular shipment will conform exactly to the values given.



# NAN YA PLASTICS CORPORATION, AMERICA SOUTH CAROLINA PLANT

140 E BEULAH ROAD, LAKE CITY, SOUTH CAROLINA  
P.O. BOX 939, LAKE CITY, SC 29560  
TEL 843-389-7800 FAX 843-389-6894

## Tairilin Chip General Specifications

Specification: CNGFA080  
Description: A-grade Bottle Resin  
Lot No: AA20

Property	Unit	General Specification	Test Method
A. IV (Intrinsic Viscosity)	dL/g	0.800 ± 0.02	NALC-QC-104
B. Color 1. L, Luminance 2. b, Yellowness		84.0 ± 3.0 -2.0 ± 3.0	NALC-QC-106
C. Melting Point	°C	246 ± 3	NALC-QC-115
D. Acetaldehyde Content	ppm	< 1.00	NALC-QC-410

1. Nan Ya PET resin complies with the U.S. FDA Code of Federal Regulations Title 21 part 177.1630 and EC Directive 2002/72/EC with respect to its use for food contact applications.

2. Typical drying conditions:

Maximum acceptable moisture level: 40ppm

Drying air temp: 160-180°C

Drying air dew point: < -40°C

Drying residence time: 4 - 6hours

3. Typical molding conditions:

Barrel temperatures: 275-285 °C

The conditions stated above are typical but not specific. Individual machine conditions will vary from machine to machine.



## PET RESIN PQS MW

*This resin targets the bottled water market but is also suitable for any product that needs superior clarity and gloss. Quality and stability allow molding in wide processing windows and designing lightweight containers. **PQS MW** is a copolymer resin formulated to provide extra clear containers with low acetaldehyde level and superior performance in the production of performs and bottles.*

### PACKAGING APPLICATIONS

- .Still water
- .Beverages
- .Edible oil
- .Food packaging
- .Pharmaceuticals
- .Cosmetics
- .Household cleaning products

## Product Specification

PARAMETER	UNIT	SPECIFICATION	TEST METHOD
Intrinsic Viscosity	dl/g	0.80 ± 0.2	ASTM D 4603
Color L*	—	Min. 87.5	HunterLab Colorimeter
Color b*	—	Max. 0	
Melting Point	°C	250	DSC
Acetaldehyde	ppm	Max. 1	GC
Fine Particles	ppm	Max. 100	Gravimetric

#### Commercial Office

Av. José Souza Campos, 243 – 10ª floor  
 ZIP: 13087-755 – Cambuí  
 Campinas/SP Phone: +55 19 3343.5200

#### Industrial Site

Road PE 60, km 10 – Zona Industrial 3B,  
 ZIP: 55590-000 - Suape  
 Ipojuca/PE Phone: +55 81 3311.4500



## **PREFORMANCE<sup>®</sup> PET 1708CC**

### ***DESCRIPTION***

**PREFORMANCE<sup>®</sup> PET 1708CC** is a food grade PET copolymer that is suitable for a wide variety of beverage and juice containers as well as many other custom containers. It is engineered for heat-set applications and offers exceptional clarity and color. The low acetaldehyde content in the resin helps eliminate any impact on aroma and flavor.

**PREFORMANCE<sup>®</sup> PET 1708CC** resin is considered safe for food packaging applications based upon compliance with FDA Regulation 21 CFR Section 177.1630 and USP 661 specifications. 1708CC also has a Drug Master File registered with the FDA.

### ***WARRANTY***

Starpet Inc. warrants that its products will comply with the specifications and related regulatory compliance detailed in its publications. No other warranty, either expressed or implied regarding the suitability of the product for any particular purpose is made. The Buyers are expected to make their own determination about the safety, health, environmental protection and suitability of use for their intended purpose. No warranty is made of the merchantability or fitness of any product, and nothing herein waives any of the Seller's conditions of sale.

July 15, 2010

## **PREFORMANCE<sup>®</sup> PET 1708CC**

### **SALES SPECIFICATION**

Polyethylene Terephthalate (PET) Resin

<b>Property</b>	<b>Value</b>	<b>Starpet Method</b>
Intrinsic Viscosity (dl/g)	0.80 ± 0.02	QSWI 8.2.4.101
Color, CIE L* b*	85 ± 2.5 -1.0 ± 2.0	QSWI 8.2.4.104
Acetaldehyde (ppm)	≤ 1.0	QSWI 8.2.4.114
Bulk Density (lbs/ft <sup>3</sup> )	56	QSWI 8.2.4.150
Dust (ppm)	≤ 300	QSWI 8.2.4.132
Moisture (wt. %)	≤ 0.25	QSWI 8.2.4.112
Contaminants/Black Specs	None	-----

**Note**

Please note that PET is hygroscopic and the moisture content can go up from the reported value during storage and transit. Also, please note that the dust value is as packed.

July 15, 2010

# 台南紡織公司太子廠

TAINAN SPINNING CO., LTD. TAITZ PLANT

## 瓶片酯粒規格表

Specification of bottle chip

批號

BT280

規格

Article

A級

Lot No

No	檢驗項目	管制界線	備註
1	特性黏度 (IV)	$0.80 \pm 0.02$	
2	羧基(meq/kg) (-COOH)	< 35	
3	b值 (b value)	$-2.0 \pm 2.0$	
4	熔點(°C) (M. P)	$246.5 \pm 3.0$	
5	乙醛(ppm) (AA)	< 1	
6	粒重(g/100粒) (g/100 chips)	$1.6 \pm 0.2$	
7	L值 (L value)	$84 \pm 2$	
8	含水率(%) (Water Content)	< 0.4	



**66N4452**  
***Masterbatch / Color Concentrate***  
***Technical Data Sheet***  
***(Typical Properties)***

**Product Description:** [Amber] masterbatch for PET beverage containers.  
Suitable for one and two stage blow molding

Color Name:	Amber
Batch Number:	L0113020147
% Carrier Resin:	55 +/- 10%
Melting Point (DSC C°)**:	215°C +/- 7%
Dosing Rate (%):	0.45%
Pellet Size:	1/16" Strand-Cut Pellet
FDA Status (21 CFR):	Raw materials used in this formulation are listed in 21 CFR. See note*
Heavy Metals (CONEG):	This product was not formulated with Heavy Metal ingredients.

\* A letter of compliance can be provided by Penn Color's Regulatory Department upon request. However, be advised it is the responsibility of the user of this product to ensure compliance with all regulations that may impact their final product.

\*\*Test Method: Equilibrate 40°C, Ramp 10.0°C/min to 300°C, Gas: Nitrogen, Pan: Tzero aluminum

*The performance of Penn Color's dispersions may vary due to the composition and applications of the final products in which they are used. It is therefore essential that they be thoroughly tested in their intended application prior to commercialization. Penn Color does not make any warranties with the respect to the merchantability or fitness for a particular purpose of any samples provided. Fitness for use must be determined and verified by the finished product formulator and will not be the liability of Penn Color. The sample which you requested is proprietary to, and contains confidential information of, Penn Color, and should not be analyzed or given to a third party for evaluation.*



***Color Concentrates for “Alpha Pkg.”  
Technical Data Sheet  
(Typical Properties)***

Date:	Thursday, September 27, 2018
Supplier:	Penn Color, Inc.
Supplier Code:	66N9936
Batch Number:	L0118070136
Color:	Amber
Letdown Resin:	PET
Mix Ratio / Letdown Ratio:	0.45%
Pellet Size:	1/16” x 1/16” Strand Cut Pellet
End Application:	Bottle

**\*Compliance documentation can be provided by Penn Color’s Regulatory Department upon request. However, be advised it is the responsibility of the user of this product to ensure compliance with all regulations that may impact their final product.**

*The performance of Penn Color’s dispersions may vary due to the composition and applications of the final products in which they are used. It is therefore essential that they be thoroughly tested in their intended application prior to commercialization. Penn Color does not make any warranties with the respect to the merchantability or fitness for a particular purpose of any samples provided. Fitness for use must be determined and verified by the finished product formulator and will not be the liability of Penn Color. The sample which you requested is proprietary to, and contains confidential information of, Penn Color, and should not be analyzed or given to a third party for evaluation.*

400 Old Dublin Pike  
Doylestown, PA 18901  
215.345.6550

2755 Bergey Road  
Hatfield, PA 19440  
215.997.2221

540 Hackett Mill Road  
Ringgold, GA 30736  
706.937.9200

30 Paul Kohner Place  
Elmwood Park, NJ 07407  
201.791.5100

1474 Putman Parkway  
Milton, WI 53563

Smakterweg 31  
5804 AE Venray  
The Netherlands  
+31.478.554000

Plot 808/C Dr. B.A. Road  
Dadar, T.T.  
Mumbai 400-014 India  
+91.22.2414.0020



R. 375  
[9,53]

SEE DETAIL A

4.311  
[109,5]  
3.593  
[91,26]

R. 188  
[4,78]

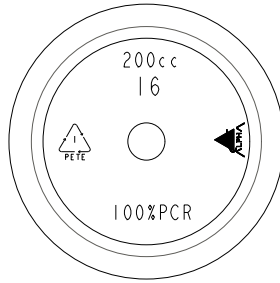
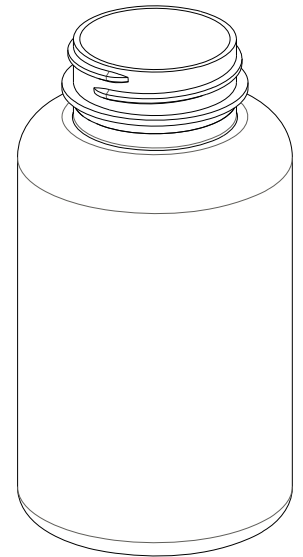
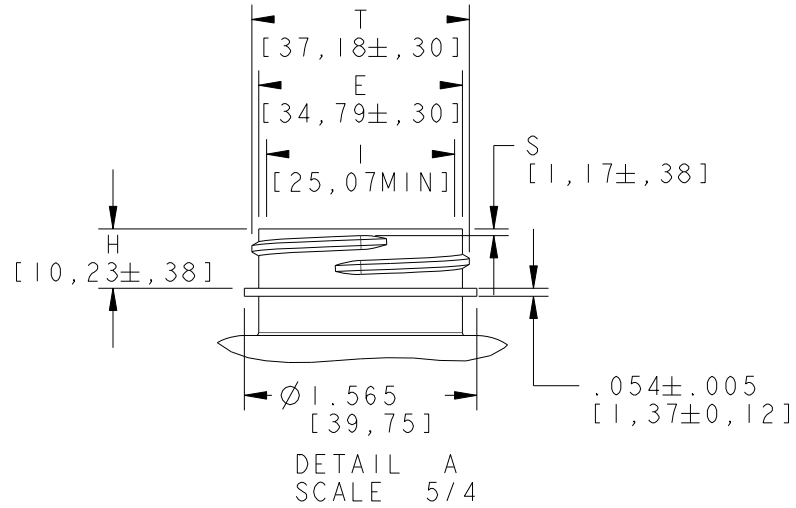

ALT BOTTOM PLUG CONFIG

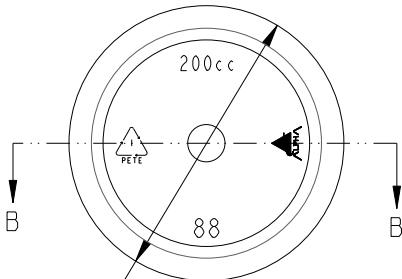
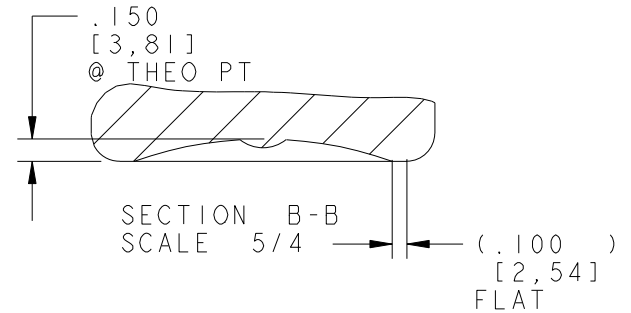

Ø 2.312±.060  
[58,72±1,52]

Neck Finish: L38SP400		<b>DISCLAIMER:</b> Alpha Packaging assumes no responsibility for form, fit and function of closures, accessories, and/or shelf life and compatibility of intended contents with this bottle.			
©Alpha Packaging, Inc. All measurements are in inches, [Metric]	Min Thk	Color	Weight	Std. Pack	Revisions
	.012[.30] .014[.35]	All Colors	24 Gms±3 26 Gms±3	335, Stack 310, Bulk	F Oah was 4.281.01-24-07.sct G Add Metric 5/3/10.sct H Add 26g 6/17/10.sct J Add Alt Config 11/4/10.sct K Wt was ±1.971713.sct
Neck Dimensions: T = 1.464±.012 E = 1.370±.012 H = .403±.015 I = .987 MIN S = .046±.015					Tolerance: Where not shown Decimal ±0.05 [1,27] Angular ±1°
			Overflow Capacity: 24l ml ± 7		Material: PET
					 <b>Alpha Packaging, Inc.</b> (314) 427-4300-(800) 421-4772 Scale: 1/1   Drawn By: SCT   Date: 07-25-00 <b>200cc, PACKER, STRAIGHT, 38-400 CT, PET</b> 200S38PET Approved By: SJ   Drawing NO: 200PS1XX38L400

**K**