

EASTLON PET CB-602 (CLEAR)

PHYSICAL PROPERTY DATA SHEET

Product Name : EASTLON PET CB-602
Chemical Name : Poly (Ethylene Terephthalate - Isophthalate)
Formula : $(\text{OCOC}_6\text{H}_4\text{COOCH}_2\text{CH}_2)_n$
Manufacturer : FAR EASTERN NEW CENTURY CORPORATION
33F No. 207 Sec 2 Tun Hwa S. RD Taipei Taiwan
TEL: 886-2-27338000 FAX : 886-2-27368304
Version : "FGE"4235

Property, Units	Test Method	Value
Density, g/cm ³	ASTM-D-1505	1.40
Bulk Density, lb/ft ³ (kg/m ³) Poured Vibrated	ASTM-D-1895	49 (785) 54 (870)
Melt Density, @285°C, g/cm ³	-	1.2
Molecular Number average (Mn)	-	28,000
Molecular Weight average (Mw)	-	42,000
Intrinsic viscosity *	ASTM-D-4603	0.80 ± 0.02
Crystallinity, %	-	> 45
Crystalline Peak Melting Point, °C	ASTM-D-3418	250 ± 5
Heat of Fusion, cal/g (j/kg)	DSC	14 (58 * 10 ³)
Thermal Conductivity, Cal/cm°C . S(W/m.k)	ASTM-D-177	6.5*10 ⁻⁴ (0.27)
Acetaldehyde, ppm	Celanese-Method	< 1.0
Diethylene Glycol, % by wt.	-	1.3 ± 0.2
Pellets Weight, g/100 grains	-	1.5 ± 0.2

* Eastlon PET CB-602 is a condensation polymer produced from pure terephthalic acid (PTA), isoterephthalic acid (IPA) and ethylene glycol (EG) using a continuous polymerization.

* Packing : 1,100 or 1,050kgs in PP woven bag with PE interlining.
20bags in one 20 feet container.

* Properties reported here are typical of average lots.
FENCC makes no representation that the material in any particular shipment will conform exactly to the values given.



NAN YA PLASTICS CORPORATION, AMERICA SOUTH CAROLINA PLANT

140 E BEULAH ROAD, LAKE CITY, SOUTH CAROLINA
P.O. BOX 939, LAKE CITY, SC 29560
TEL 843-389-7800 FAX 843-389-6894

Tairilin Chip General Specifications

Specification: CNGFA080
Description: A-grade Bottle Resin
Lot No: AA20

Property	Unit	General Specification	Test Method
A. IV (Intrinsic Viscosity)	dL/g	0.800 ± 0.02	NALC-QC-104
B. Color 1. L, Luminance 2. b, Yellowness		84.0 ± 3.0 -2.0 ± 3.0	NALC-QC-106
C. Melting Point	°C	246 ± 3	NALC-QC-115
D. Acetaldehyde Content	ppm	< 1.00	NALC-QC-410

1. Nan Ya PET resin complies with the U.S. FDA Code of Federal Regulations Title 21 part 177.1630 and EC Directive 2002/72/EC with respect to its use for food contact applications.

2. Typical drying conditions:

Maximum acceptable moisture level: 40ppm

Drying air temp: 160-180°C

Drying air dew point: < -40°C

Drying residence time: 4 - 6hours

3. Typical molding conditions:

Barrel temperatures: 275-285 °C

The conditions stated above are typical but not specific. Individual machine conditions will vary from machine to machine.



PET RESIN PQS MW

*This resin targets the bottled water market but is also suitable for any product that needs superior clarity and gloss. Quality and stability allow molding in wide processing windows and designing lightweight containers. **PQS MW** is a copolymer resin formulated to provide extra clear containers with low acetaldehyde level and superior performance in the production of performs and bottles.*

PACKAGING APPLICATIONS

- .Still water
- .Beverages
- .Edible oil
- .Food packaging
- .Pharmaceuticals
- .Cosmetics
- .Household cleaning products

Product Specification

PARAMETER	UNIT	SPECIFICATION	TEST METHOD
Intrinsic Viscosity	dl/g	0.80 ± 0.2	ASTM D 4603
Color L*	—	Min. 87.5	HunterLab Colorimeter
Color b*	—	Max. 0	
Melting Point	°C	250	DSC
Acetaldehyde	ppm	Max. 1	GC
Fine Particles	ppm	Max. 100	Gravimetric

Commercial Office

Av. José Souza Campos, 243 – 10ª floor
 ZIP: 13087-755 – Cambuí
 Campinas/SP Phone: +55 19 3343.5200

Industrial Site

Road PE 60, km 10 – Zona Industrial 3B,
 ZIP: 55590-000 - Suape
 Ipojuca/PE Phone: +55 81 3311.4500



PREFORMANCE[®] PET 1708CC

DESCRIPTION

PREFORMANCE[®] PET 1708CC is a food grade PET copolymer that is suitable for a wide variety of beverage and juice containers as well as many other custom containers. It is engineered for heat-set applications and offers exceptional clarity and color. The low acetaldehyde content in the resin helps eliminate any impact on aroma and flavor.

PREFORMANCE[®] PET 1708CC resin is considered safe for food packaging applications based upon compliance with FDA Regulation 21 CFR Section 177.1630 and USP 661 specifications. 1708CC also has a Drug Master File registered with the FDA.

WARRANTY

Starpet Inc. warrants that its products will comply with the specifications and related regulatory compliance detailed in its publications. No other warranty, either expressed or implied regarding the suitability of the product for any particular purpose is made. The Buyers are expected to make their own determination about the safety, health, environmental protection and suitability of use for their intended purpose. No warranty is made of the merchantability or fitness of any product, and nothing herein waives any of the Seller's conditions of sale.

July 15, 2010

PREFORMANCE[®] PET 1708CC

SALES SPECIFICATION

Polyethylene Terephthalate (PET) Resin

Property	Value	Starpet Method
Intrinsic Viscosity (dl/g)	0.80 ± 0.02	QSWI 8.2.4.101
Color, CIE L* b*	85 ± 2.5 -1.0 ± 2.0	QSWI 8.2.4.104
Acetaldehyde (ppm)	≤ 1.0	QSWI 8.2.4.114
Bulk Density (lbs/ft ³)	56	QSWI 8.2.4.150
Dust (ppm)	≤ 300	QSWI 8.2.4.132
Moisture (wt. %)	≤ 0.25	QSWI 8.2.4.112
Contaminants/Black Specs	None	-----

Note

Please note that PET is hygroscopic and the moisture content can go up from the reported value during storage and transit. Also, please note that the dust value is as packed.

July 15, 2010

台南紡織公司太子廠

TAINAN SPINNING CO., LTD. TAITZ PLANT

瓶片酯粒規格表

Specification of bottle chip

批號

BT280

規格

Article

A級

Lot No

No	檢驗項目	管制界線	備註
1	特性黏度 (IV)	0.80 ± 0.02	
2	羧基(meq/kg) (-COOH)	< 35	
3	b值 (b value)	-2.0 ± 2.0	
4	熔點(°C) (M. P)	246.5 ± 3.0	
5	乙醛(ppm) (AA)	< 1	
6	粒重(g/100粒) (g/100 chips)	1.6 ± 0.2	
7	L值 (L value)	84 ± 2	
8	含水率(%) (Water Content)	< 0.4	

Holland Colours Americas Inc.

1501 Progress Drive
Richmond, IN 47374
Phone (765) 935-0329
Fax (765) 966-3376

TECHNICAL DATA SHEET

Holcoprill[®] White 175.3167

Product Description	Colorants/Additives in a non-polymeric carrier
Physical Form	Solid Bead
Melt Temperature	85-88°C
Specific Gravity	2.33-2.53 g/cm ³



For additional information, refer to the MSDS and specifications for this product.

Holland Colours Americas Inc. does not control the conditions under which its products are used. Therefore we are not in a position to warrant that our customers' products are suitable for their intended use. Holland Colours Americas Inc. recommends that the customer perform their own tests to ensure acceptable performance.

CONFIDENTIAL

Created on 5/29/2008

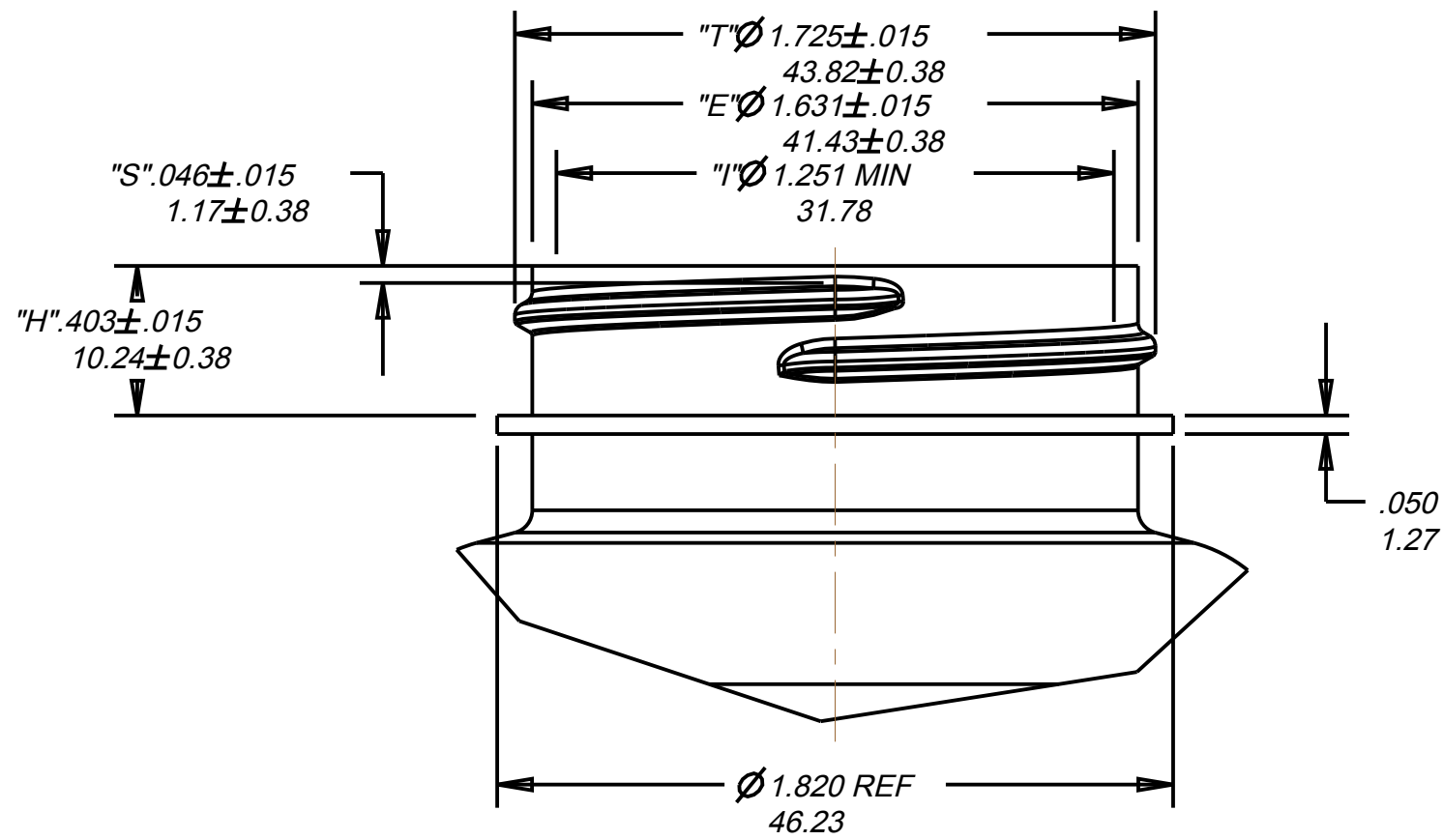
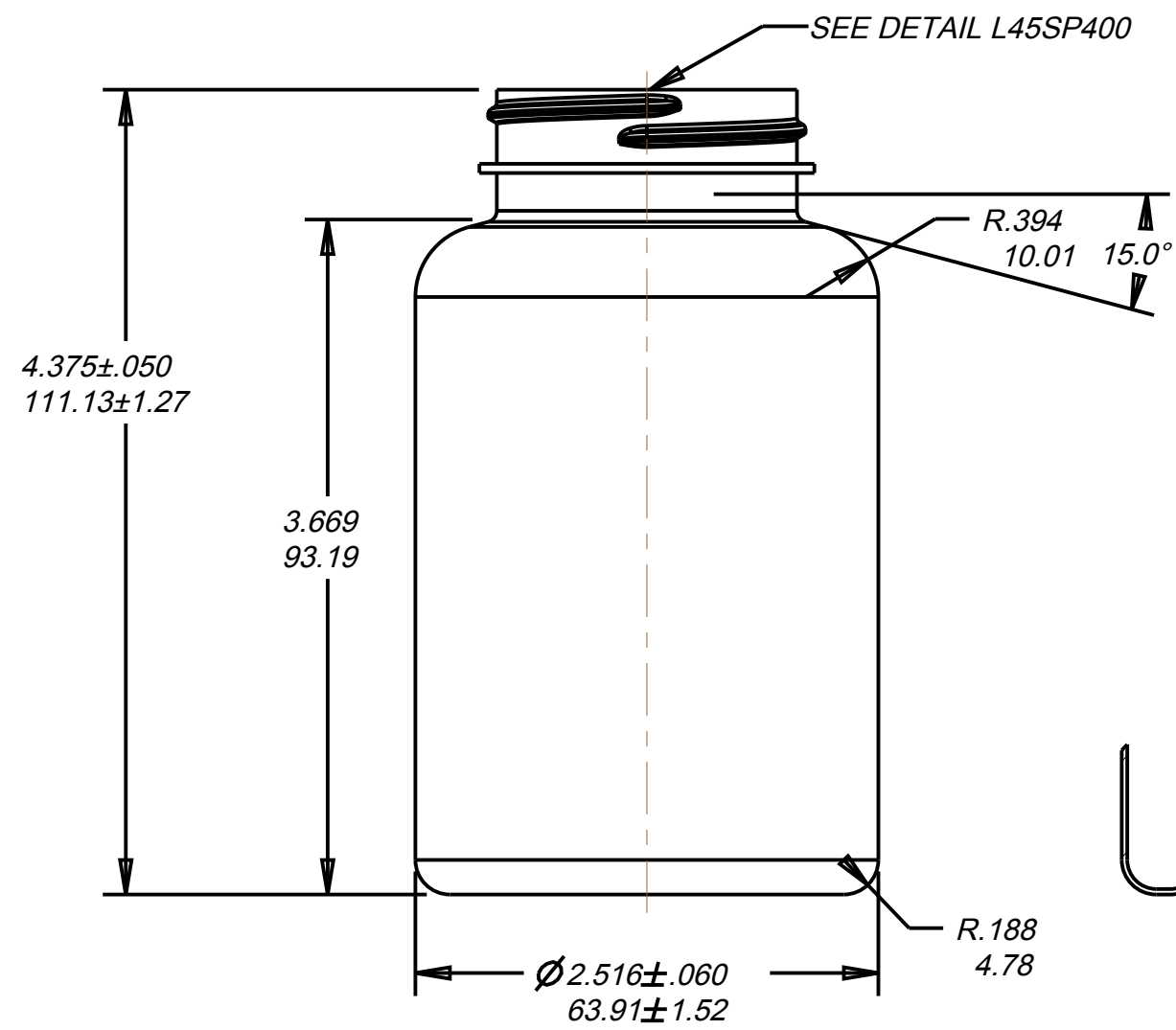

DETAIL L45SP400
6 TPI, 1 THREAD TURN
Ø.500" CUTTER
SCALE 2.000

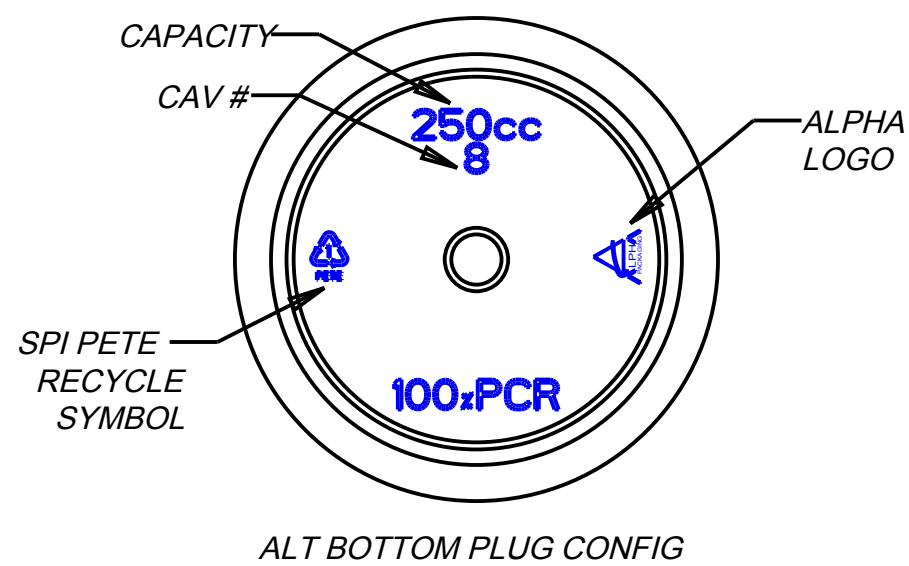
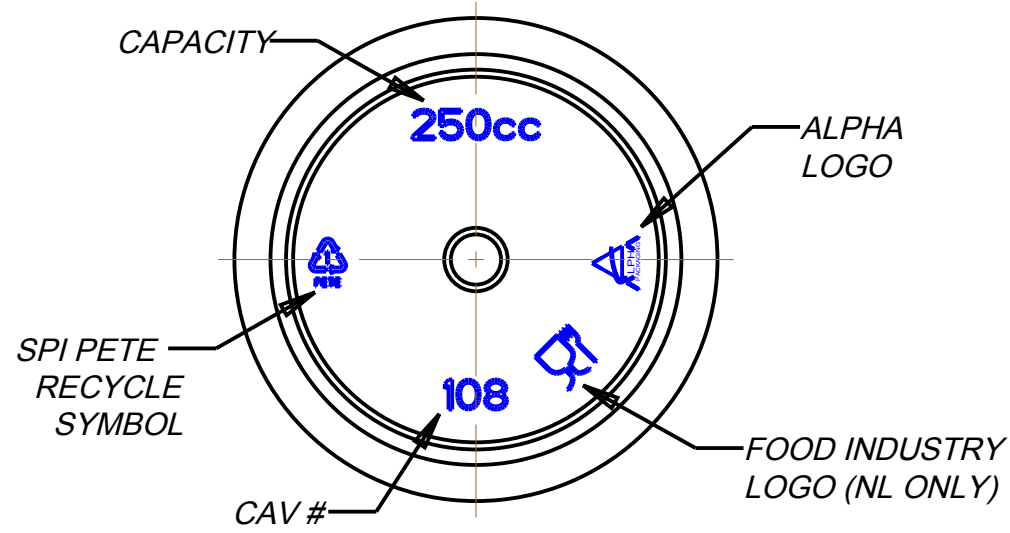
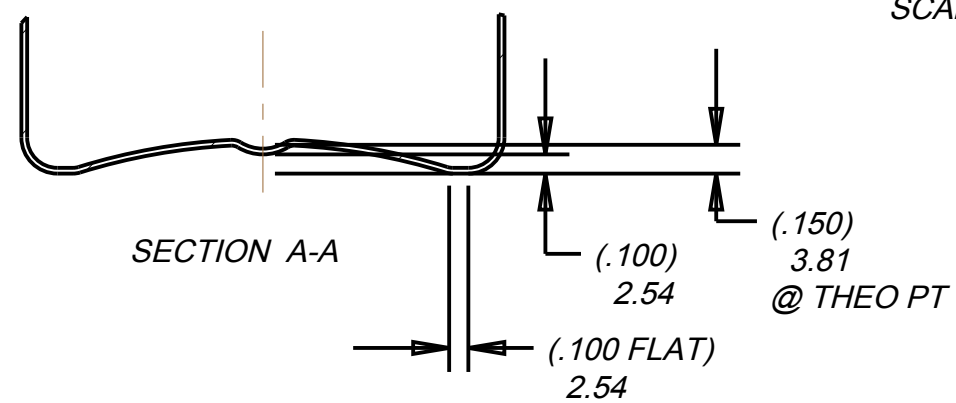

NPD #		DISCLAIMER: Alpha Packaging assumes no responsibility for form, fit and function of closures, accessories, and/or shelf life and compatability of intended contents with this bottle.				
© Alpha Packaging, Inc. All measurements are in inches, [mm]	Color	Min. Thk (in)	Weight (g)	Overflow (mL)	Revisions	
	All Colors	.012[.30]	28.0± 3.0	292± 9	L	Gm wt was 34, 02-09-12, sct
	All Colors	.012[.30]	37.0± 3.0	284± 9	M	GmWt tol was ± 1, 11/13/13, sct
	Heavy Gram 400 P	.012[.30]	33.0± 3.0	288± 9	N	Add Food Logo engraving for NL, 11-18-15 RAB
Tolerance: Where not shown	NECK FINISH	L45SP400			250 CC, STRAIGHT SIDED, PET 45-400 CT	
Decimal ±.05 [1.27] Angular ±1°	MATERIAL:	PET			250S45PET	
					Scale: 1.000	Drawn By: SCT
					Date: 07-25-00	DwgRev
					Approved By:	Drawing NO:
					SJ	250PS1XX45L400

Alpha Packaging, Inc.
 (314) 427-4300--(800) 421-4772
 Scale: 1.000 Drawn By: SCT Date: 07-25-00
 250 CC, STRAIGHT SIDED, PET 45-400 CT
 250S45PET
 Approved By: Drawing NO:
 SJ 250PS1XX45L400