



Laser+[®] C 9000 (B64A)

polyethylene terephthalate resin

Product Information

General

Laser+[®] C 9000 (B64A) is a unique copolymer particularly suited for use in the custom PET container applications where clarity and neutral color are desired. It is a medium intrinsic viscosity (IV) product that gives the end user a strong clear bottle and offers excellent processing and consistency.

Product Description

Bi-orientation of Laser+[®] C 9000 (B64A) by injection/stretch blow molding provides optimal barrier and mechanical properties, including excellent vacuum performance. It performs well in both single- and two-stage processes used in the manufacturing of PET containers.

Laser+[®] C 9000 (B64A) offers excellent clarity and color, while maintaining good reheat characteristics for stretch blow molding. In addition, because it is a copolymer resin, it offers reduced crystallization rates and a wide processing window.

Sales Specifications

Property	Value	Test Method
Intrinsic Viscosity	0.84 ± 0.02	DAK-QAR-SOP-0012
Color L* CIE	72.5 min	DAK-QAR-SOP-0011
Color b* CIE	-3.4 ± 1.4	
Acetaldehyde	2 ppm max	DAK-QAR-SOP-0010

Certification

Laser+[®] C 9000 (B64A) is ideally suited for food packaging applications and is considered in compliance with the Food and Drug Administration (FDA) Food Contact Notification (FCN) 000635, and Health Canada Health Products and Food Branch (HPFB) file KS 11051909 for PET polymers.

Typical Properties

Property	Value	Test Method
Mositure Content ¹	0.25% max	DAK-QAR-SOP-0013
Fines ¹ , +24 Mesh	0.05% max	DAK-QAR-SOP-0014
Pellet Size, nominal	30 chips/g	DAK-QAR-SOP-0015
Crystallinity	>35%	DAK-QAR-SOP-0016
Spherical Shape	3.4 mm	DAK-QAR-SOP-0017
Melt Point, nominal	243°C	DAK-QAR-SOP-0016
Bulk Density	51 lb / ft ³	DAK-QAR-SOP-0018

¹ As packaged

These values represent the anticipated performance data for these polyester resins and intermediates; they are not intended to be used as design data. We believe this information is the best currently available on the subject. It is offered as a possible helpful suggestion in the experimentation you may care to undertake along these lines. It is subject to revision as additional knowledge and experience is gained. DAK makes no guarantee of results and assumes no obligation or liability whatsoever in connection with this information. This publication is not a license to operate under, or intended to suggest infringement of, any existing patents.

CAUTION: Do not use in medical applications involving permanent implantation in the human body. For other medical applications, see "DAK Medical Caution Statement".



ISO 9001
10004457



FSSC 22000 PAS 223
10004457

DAK Americas LLC
Gateway Corporate Center, Suite 210
223 Wilmington W Chester Pike • Chadds Ford, PA 19317
1-888-738-2002 • fax: 610-558-7385 • www.dakamericas.com

PDS-B64A 150303KH



Laser+[®] C 9000 (B64A)

polyethylene terephthalate resin

Product Information

Material Drying

Proper drying of polyethylene terephthalate (PET) is essential to produce a high quality part (container, film, etc.) with optimum physical properties. PET is hygroscopic, meaning that when it is exposed to humid atmospheres, it will absorb moisture. In PET the moisture is not only on the surface but diffuses slowly through the whole pellet and is firmly held by molecular attraction. Before processing the PET, this moisture must be removed. Carefully controlled drying of all PET is an essential requirement for optimum processing performance and final product properties. If drying is not carried out properly, to the known requirements of the type of PET in use, then deficiencies in process and product will result. The deficiencies will be impossible to remedy by later process changes. These defects arise in the injection molding or extrusion processes because at PET melt temperature (250°-280° C) any water present causes hydrolytic degradation of the PET, almost instantaneously, with the resultant loss in intrinsic viscosity (IV). Significant drops in IV cause loss of process control and reductions in end product properties.

Drying of PET polymer involves the diffusion of absorbed moisture from the interior of the polymer chip to its surroundings and, subsequently the removal of moisture from the bulk of polymer chips. Moisture removal can be achieved by heating the polymer chip under dry air or vacuum. In an air drying system, heated dehumidified air flows up through a chip bed and returns to the dehumidifier. The key requirements for a reliable drying process are:

Drying temperature: The ACTUAL chip temperature should achieve between 300° and 330° F measured at the dryer exit.

Dehumidified air temperature: Correctly designed equipment should operate at temperatures up to 340° F measured on entry to the dryer hopper, with an absolute maximum of 350° F to prevent possible discoloration.

Dehumidified air dew point: This should not be allowed to rise above -34° F and should preferably be -40° F or lower, measure after the desiccant bed. Always check the correct regeneration temperatures are being used.

Dehumidified air flow through the chip bed: Most dryers operate at around 1 CFM of airflow per 1lb/hr of PET chip as a minimum requirement, with the airflow at the correct temperature and dew point.

Chip residence time (drying time): DAK recommends a chip residence time for Laser+[®] PET of not less than four hours and preferably six hours. This is the theoretical drying time, which is calculated by dividing dryer capacity in lbs. by throughput in lb./hr. Extended periods of high temperature can adversely affect the polymer processing conditions. In the event of a stoppage for an extended period, dry polymer can be stored in the dryer-hopper by reducing the air temperature to 240° F (or even lower).

Important Start-Up and Shut-Down Procedures:

Dryer Start-Up Conditions

- When beginning to dry a "wet" load of pellets, start drying at reduced temperatures 135 to 150°C (275 to 300°F) for 2 hours
- Raise the drying temperature to a maximum of 165°C (330°F) for a single stage drying system for the remaining start-up drying time (2-4 additional hours)

Dryer Running Conditions

- When running the injection molding machine, it is recommended to not exceed 170°C (340°F)
- Absolute maximum drying condition is 175°C (350°F).
- When higher operational temperatures are used, care should be taken if the machine stops production (idle time of 20+ minutes) to reduce the drying temperature down to a maximum of 165°C (330°F) and preferred to be at or below 150°C (300°F).

Shutting Down Dryers

- Ensure pellet temperature is cooled to below 120°C (250°F) prior to shutting down process air blower
- Time required to reduce the pellet temperature varies on ambient conditions, equipment configuration, and air flow capacity
- If pellets reside in drying vessel above the recommended cooled pellet temperature, degradation can occur (IV loss and yellowing)

Note: When a stoppage occurs for an extended period of time, dry resin pellets may be stored in the drying vessel at a reduced air temperature of 115°C (240°F). Drying of these pellets will not then be necessary, only increasing of the pellet temperature will be required to restart the system.



ISO 9001
10004457



FSSC 22000 PAS 223
10004457

DAK Americas LLC
Gateway Corporate Center, Suite 210
223 Wilmington W Chester Pike • Chadds Ford, PA 19317
1-888-738-2002 • fax: 610-558-7385 • www.dakamericas.com

PDS-B64A 150303KH

PERFORMANCE[®] PET 1708CC(A)

Sales Description, Documents

PERFORMANCE[®] PET 1708CC(A) resin is a food grade PET copolymer that is used for various types of custom containers, including beverage and juice containers. It offers exceptional clarity and color. The low acetaldehyde content in the resin helps eliminate any impact on aroma and flavor.

PERFORMANCE[®] PET 1708CC(A) resin is considered safe for food packaging applications based upon compliance with FDA Regulation 21 CFR Section 177.1630 specifications.

WARRANTY

AlphaPet Inc. warrants that its products will comply with the specifications and related regulatory compliance detailed in its publications. No other warranty, either expressed or implied regarding the suitability of the product for any particular purpose is made. The Buyers are expected to make their own determination about the safety, health, environmental protection and suitability of use for their intended purpose. No warranty is made of the merchantability or fitness of any product, and nothing herein waives any of the Seller's conditions of sale.

ALPHAPET INC.

(A subsidiary of Indorama Ventures Public Company Limited)
1301, Finley Island Road, Decatur, Alabama, AL35601, USA
Tel. (256) 308 1180 Fax. (256) 341 5926
www.indoramaventures.com

PERFORMANCE® PET 1708CC(A)

Sales Specification, Documents

Polyethylene Terephthalate (PET) Resin

Property	Value	AlphaPet Method
Intrinsic Viscosity (dl/g)	0.80 ± 0.02	QCL-03-0015
Color, CIE L* b*	≥ 78.0 -1.5 ± 2.5	QCL-03-0009
Acetaldehyde (ppm)	≤ 2.0	QCL-03-0001
Bulk Density (lbs/ft ³)	53 ± 2.0	QCL-03-0004
Dust (ppm)* as packed	≤ 300	QCL-03-0014
Moisture (wt. %)* as packed	≤ 0.25	QCL-03-0011
Contaminants/Black Specs	None	QCL-03-0028

Notes:

Please note that PET is hygroscopic and the moisture content can go up from the reported value during storage and transit. Also please note that the dust value is as packed.

ALPHAPET INC.

(A subsidiary of Indorama Ventures Public Company Limited)
 1301, Finley Island Road, Decatur, Alabama, AL35601, USA
 Tel. (256) 308 1180 Fax. (256) 341 5926
www.indoramaventures.com



155 E. Steels Corners Rd. | Cuyahoga Falls, OH 44224 | **p:** 330.926.4000 | **f:** 330.926.2055
americhem.com

PRODUCT TECHNICAL INFORMATION SHEET

Product Code:	63809-CD2-100
Color:	Amber
Application:	FDA PET Bottles
Let-Down Ratio:	2 pph
Pellet form:	Cylindrical or Spherical Pellet
Melt Temperature:	>240 °C
Specific Gravity:	1.39

Please contact Americhem Customer Service at 330.926.4000 in North America or (44) 161.789.7832 in Europe for further information.

6-18-2018

Approved By: _____
 Date: _____

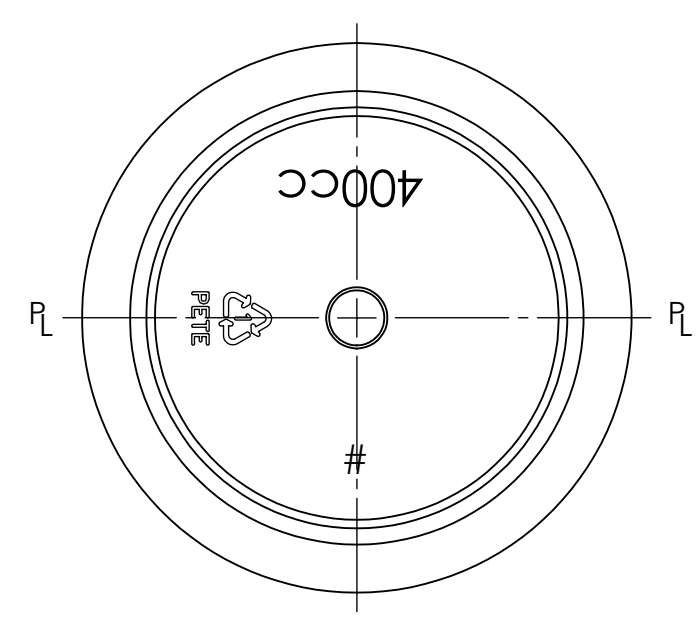
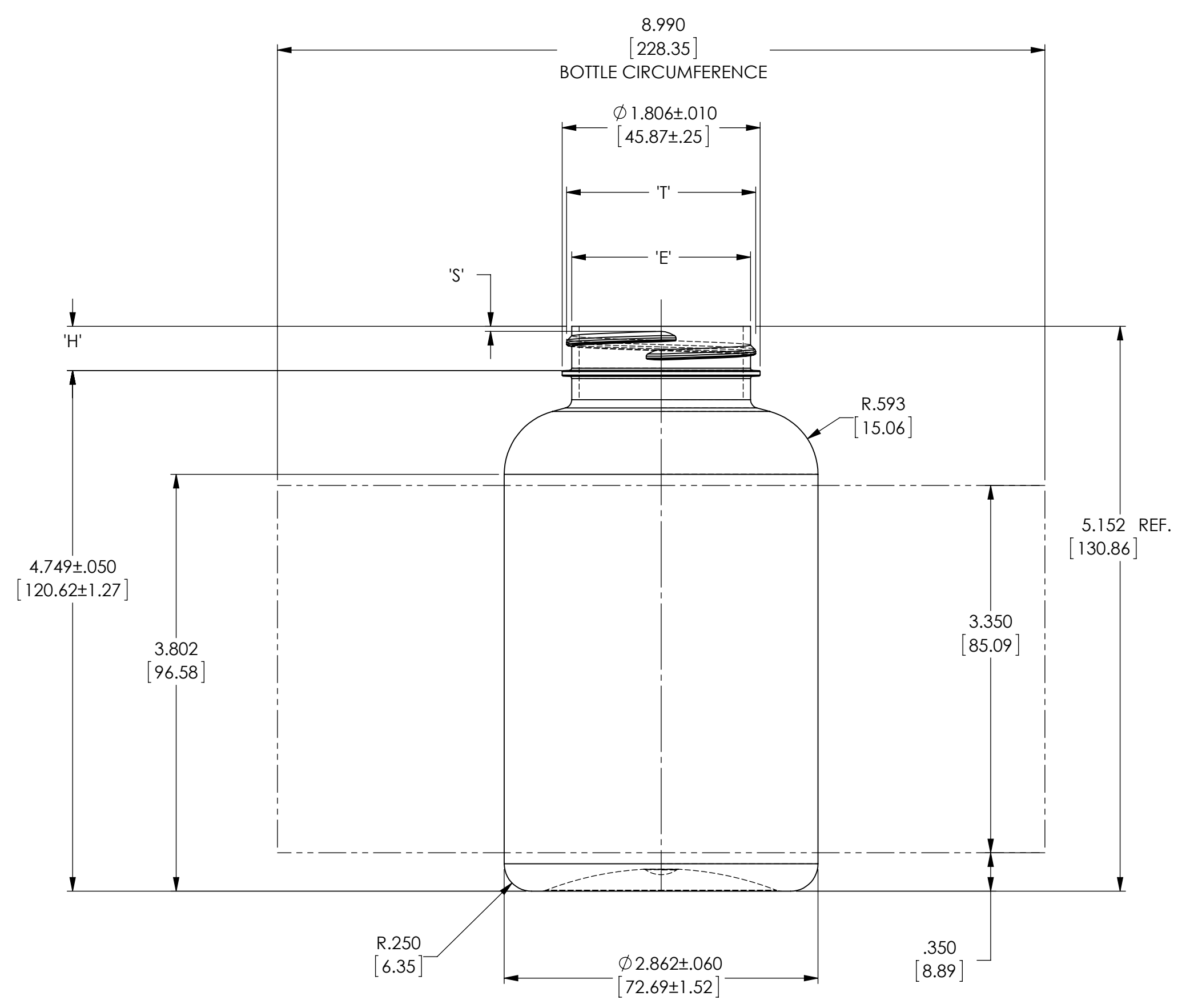

No.	Rev.	By.	Description	Date	
Neck Finish: M45-SP400			Gram Wt.: 37 ±1.0		
'T'	'E'	'H'	'S'	'L'	'W'
1.725 ±.014	1.631 ±.014	.403 ±.015	.046 ±.015		
43.81 ±0.35	41.43 ±0.35	10.24 ±0.38	1.17 ±0.38		
HELIX ANGLE: 1°49'		T.P.I.: 6	CUTT. DIA.: .500 [12.70]		
Capacity to fill level before decorating _____					
Capacity to fill level after decorating _____					
Overflow capacity before decorating			445ml ±11		
Overflow capacity after decorating _____					
Drawn By: i.d.			Desc. 400cc PACKER		
Scale: 1-1		Date: APR. 4/13	Drawing No. AX-1164-0		
Bottle Mat'l: PETE			Mould No.		
Cad Name:					

No representation & warranties are made about the performance of product.
 This bottle is designed and produced as per your specifications.

This drawing subject to standard industry tolerances S.P.I