



Laser+[®] C (C60A)

polyethylene terephthalate resin

Product Information

Product Description

Laser+[®] C (C60A) is a unique copolymer particularly suited for use in the custom PET container applications where clarity and neutral color are desired. It is a medium intrinsic viscosity (IV) product that gives the end user a strong clear bottle and offers excellent processing and consistency.

Typical Properties

Bi-orientation of Laser+[®] C (C60A) by injection/stretch blow molding provides optimal barrier and mechanical properties, including excellent vacuum performance. It performs well in both single- and two-stage processes used in the manufacturing of PET containers.

Laser+[®] C (C60A) offers excellent clarity and color, while maintaining good reheat characteristics for stretch blow molding. In addition, because it is a copolymer resin, it offers reduced crystallization rates and a wide processing window.

Certification

Laser+[®] C (C60A) is ideally suited for food packaging applications and is considered in compliance with the Food and Drug Administration (FDA) Food Contact Notification (FCN) 000635, covering PET polymers.

Sales Specifications

Property	Value	Unit	Test Method
Intrinsic Viscosity	0.83 ± 0.02	dL/g	DAK-QAR-SOP-0012
Color L*	87 ± 2.0	CIE	DAK-QAR-SOP-0011
Color b*	-3.0 ± 2.0	CIE	DAK-QAR-SOP-0011
Acetaldehyde	2 max	ppm	DAK-QAR-SOP-0010
Moisture Content (as packaged)	0.25 max	weight %	DAK-QAR-SOP-0013
Fines (as packaged, +24 Mesh Size)	0.10 max	weight %	DAK-QAR-SOP-0014
Chip Size, nominal	53 ± 5	chips / g	DAK-QAR-SOP-0015
Crystallinity	> 45	%	DAK-QAR-SOP-0016
Partical Size, Shape (Flat Cylinder)	3x3x2	mm	DAK-QAR-SOP-0017
Melting Point, nominal	246	°C	DAK-QAR-SOP-0016
Bulk Density	54.3	lb / ft ³	DAK-QAR-SOP-0018

These values represent the anticipated performance data for these polyester resins and intermediates; they are not intended to be used as design data. We believe this information is the best currently available on the subject. It is offered as a possible helpful suggestion in the experimentation you may care to undertake along these lines. It is subject to revision as additional knowledge and experience is gained. DAK Resins makes no guarantee of results and assumes no obligation or liability whatsoever in connection with this information. This publication is not a license to operate under, or intended to suggest infringement of, any existing patents.

CAUTION: Do not use in medical applications involving permanent implantation in the human body. For other medical applications, see "DAK Medical Caution Statement".



DAK Americas
ISO 9001:2008
#10004457

DAK Americas LLC
Gateway Corporate Center, Suite 210
223 Wilmington W Chester Pike • Chadds Ford, PA 19317
1-888-738-2002 • fax: 610-558-7385 • www.dakamericas.com

PDS-C60A Rev 06/11



Laser+[®] C (C60A)

polyethylene terephthalate resin

Product Information

Material Drying

Proper drying of polyethylene terephthalate (PET) is essential to produce a high quality part (container, film, etc.) with optimum physical properties. PET is hygroscopic, meaning that when it is exposed to humid atmospheres, it will absorb moisture. In PET the moisture is not only on the surface but diffuses slowly through the whole pellet and is firmly held by molecular attraction. Before processing the PET, this moisture must be removed. Carefully controlled drying of all PET is an essential requirement for optimum processing performance and final product properties. If drying is not carried out properly, to the known requirements of the type of PET in use, then deficiencies in process and product will result. The deficiencies will be impossible to remedy by later process changes. These defects arise in the injection molding or extrusion processes because at PET melt temperature (250°-280° C) any water present causes hydrolytic degradation of the PET, almost instantaneously, with the resultant loss in intrinsic viscosity (IV). Significant drops in IV cause loss of process control and reductions in end product properties.

Drying of PET polymer involves the diffusion of absorbed moisture from the interior of the polymer chip to its surroundings and, subsequently the removal of moisture from the bulk of polymer chips. Moisture removal can be achieved by heating the polymer chip under dry air or vacuum. In an air drying system, heated dehumidified air flows up through a chip bed and returns to the dehumidifier. The key requirements for a reliable drying process are:

Drying temperature: The ACTUAL chip temperature should achieve between 300° and 340° F measured at the dryer exit.

Dehumidified air temperature: Correctly designed equipment should operate at temperatures up to 340° F measured on entry to the dryer hopper, with an absolute maximum of 370° F to prevent possible discoloration.

Dehumidified air dew point: This should not be allowed to rise above -34° F and should preferably be -40° F or lower, measure after the desiccant bed. Always check the correct regeneration temperatures are being used.

Dehumidified air flow through the chip bed: Most dryers operate at around 1 cfm of airflow per 1lb/hr of PET chip as a minimum requirement, with the airflow at the correct temperature and dew point.

Chip residence time (drying time): DAK recommends a chip residence time for Laser+[®] PET of not less than four hours and preferably six hours. This is the theoretical drying time, which is calculated by dividing dryer capacity in lbs. by throughput in lb./hr. Extended periods of high temperature can adversely affect the polymer processing conditions. In the event of a stoppage for an extended period, dry polymer can be stored in the dryer-hopper by reducing the air temperature to 240° F (or even lower).



DAK Americas
ISO 9001:2008
#10004457

DAK Americas LLC
Gateway Corporate Center, Suite 210
223 Wilmington W Chester Pike • Chadds Ford, PA 19317
1-888-738-2002 • fax: 610-558-7385 • www.dakamericas.com

PDS-C60A Rev 06/11



NAN YA PLASTICS CORPORATION, AMERICA SOUTH CAROLINA PLANT

140 E BEULAH ROAD, LAKE CITY, SOUTH CAROLINA
P.O. BOX 939, LAKE CITY, SC 29560
TEL 843-389-7800 FAX 843-389-6894

Tairilin Chip General Specifications

Specification: CNGFA080
Description: A-grade Bottle Resin
Lot No: AA20

Property	Unit	General Specification	Test Method
A. IV (Intrinsic Viscosity)	dL/g	0.800 ± 0.02	NALC-QC-104
B. Color 1. L, Luminance 2. b, Yellowness		84.0 ± 3.0 -2.0 ± 3.0	NALC-QC-106
C. Melting Point	°C	246 ± 3	NALC-QC-115
D. Acetaldehyde Content	ppm	< 1.00	NALC-QC-410

1. Nan Ya PET resin complies with the U.S. FDA Code of Federal Regulations Title 21 part 177.1630 and EC Directive 2002/72/EC with respect to its use for food contact applications.

2. Typical drying conditions:

Maximum acceptable moisture level: 40ppm

Drying air temp: 160-180°C

Drying air dew point: < -40°C

Drying residence time: 4 - 6hours

3. Typical molding conditions:

Barrel temperatures: 275-285 °C

The conditions stated above are typical but not specific. Individual machine conditions will vary from machine to machine.



***Color Concentrates for “Comar Products”
Technical Data Sheet
(Typical Properties)***

Date:	Monday, July 09, 2018
Supplier:	Penn Color, Inc.
Supplier Code:	66G9804
Batch Number:	L0118050196
Color:	Body Shop Green
Letdown Resin:	PET
Mix Ratio / Letdown Ratio:	0.25%
Pellet Size:	1/16” Strand-Cut Pellet
End Application:	Bottle

***Compliance documentation can be provided by Penn Color’s Regulatory Department upon request. However, be advised it is the responsibility of the user of this product to ensure compliance with all regulations that may impact their final product.**

The performance of Penn Color's dispersions may vary due to the composition and applications of the final products in which they are used. It is therefore essential that they be thoroughly tested in their intended application prior to commercialization. Penn Color does not make any warranties with the respect to the merchantability or fitness for a particular purpose of any samples provided. Fitness for use must be determined and verified by the finished product formulator and will not be the liability of Penn Color. The sample which you requested is proprietary to, and contains confidential information of, Penn Color, and should not be analyzed or given to a third party for evaluation.

400 Old Dublin Pike
Doylestown, PA 18901
215.345.6550

2755 Bergey Road
Hatfield, PA 19440
215.997.2221

540 Hackett Mill Road
Ringgold, GA 30736
706.937.9200

30 Paul Kohner Place
Elmwood Park, NJ 07407
201.791.5100

1474 Putman Parkway
Milton, WI 53563

Smakterweg 31
5804 AE Venray
The Netherlands
+31.478.554000

Plot 808/C Dr. B.A. Road
Dadar, T.T.
Mumbai 400-014 India
+91.22.2414.0020

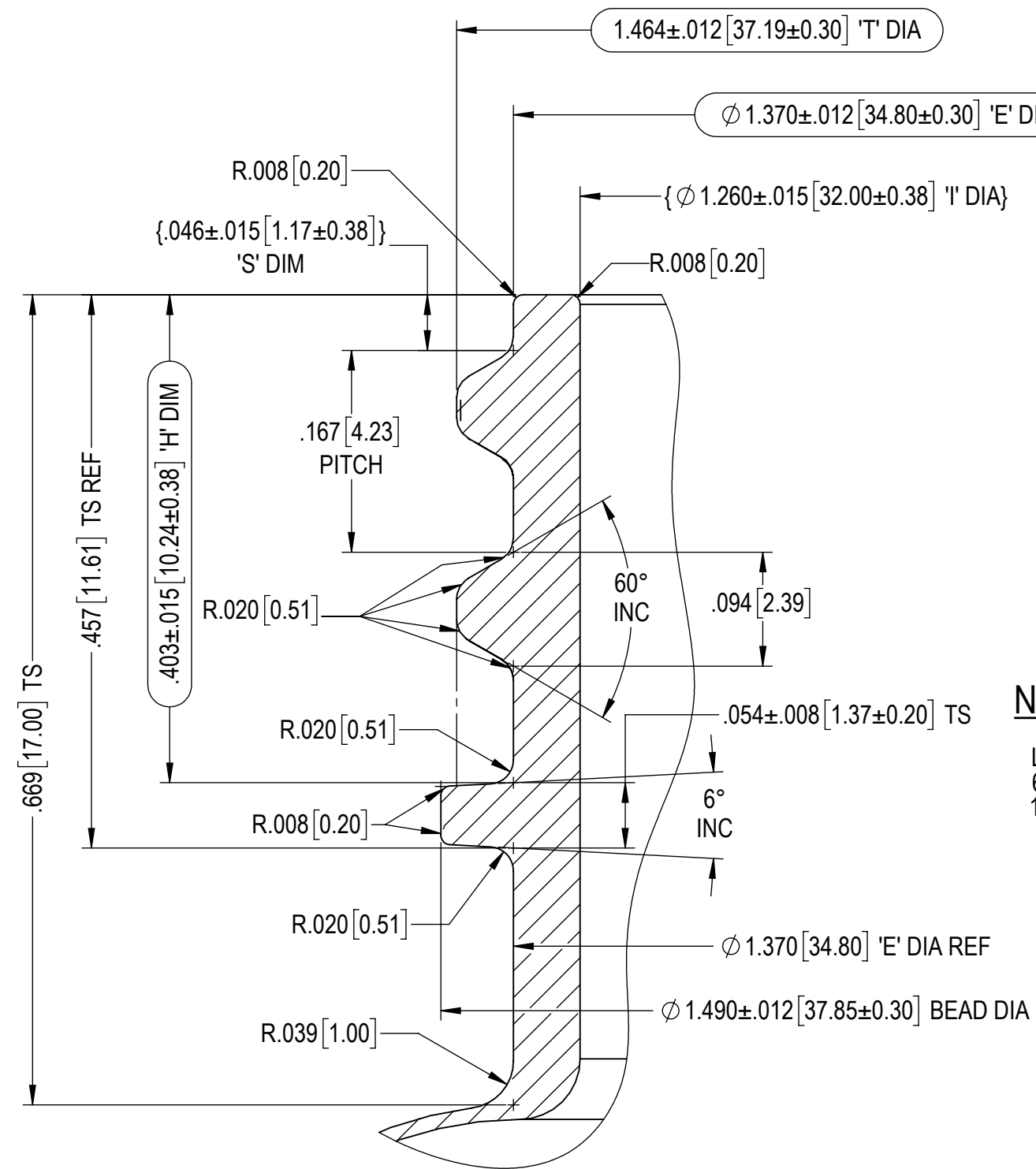
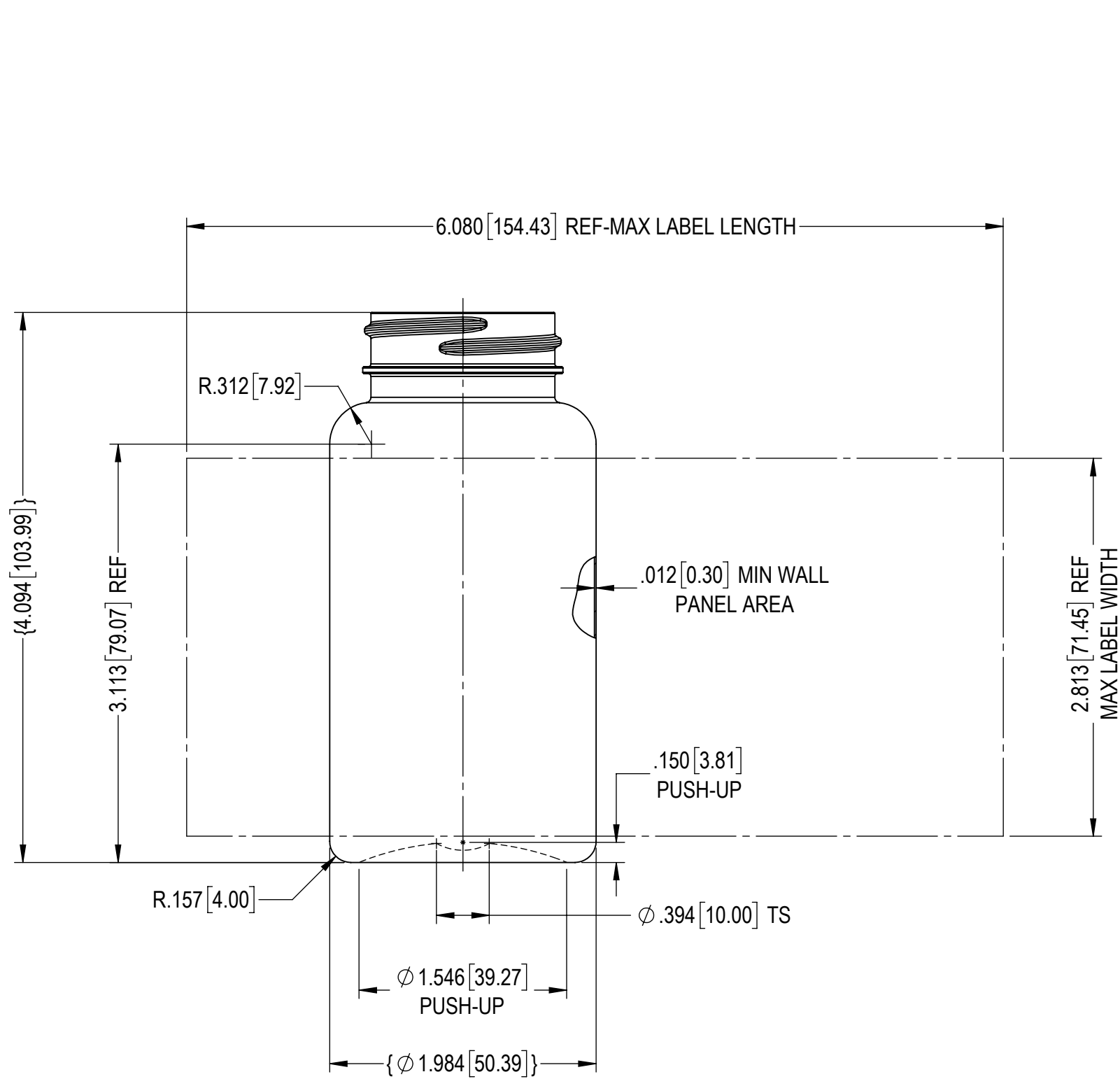

NECK DETAIL
 SCALE: 4x1
 L38SP400 FINISH
 6 TPI, .167 PITCH
 1 FULL TURN MIN

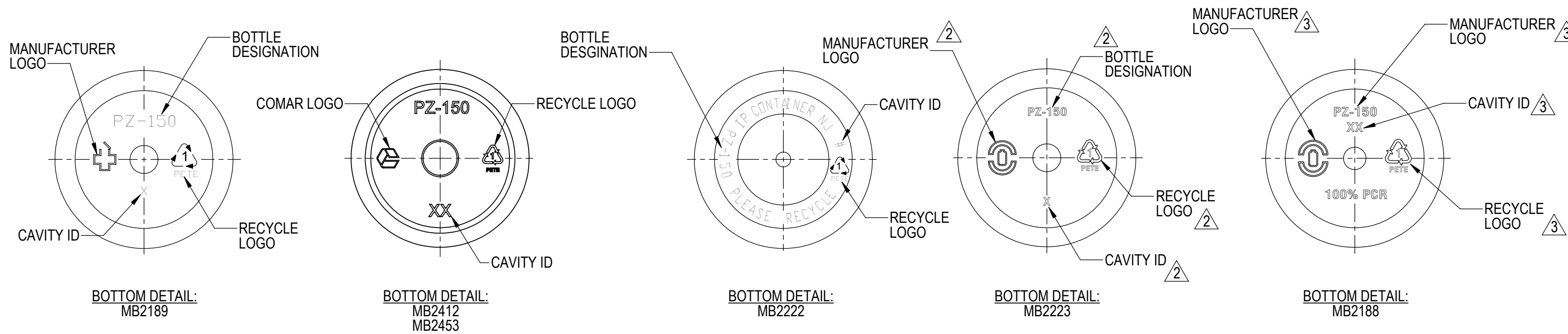

- NOTES:**
- 1) MATERIAL: PETE
 - 2) GRAM WEIGHT: {19.7 GRAMS ± 1.0 GRAMS}
 - 3) OVERFLOW CAP'Y: 170cc ± 6cc
 - 4) DIMENSIONS SHOWN IN [] ARE EXPRESSED IN MILLIMETERS
 - 5) FOR ALL UNSPECIFIED GEOMETRY, REFERENCE 3D MODEL FILE: 71-0010B_PZ-150 L38SP400 CT Neck Finish
 - 6) MIN LABEL PANEL WALL THICKNESS: .012 [.30]
 - 7) MIN HEEL WALL THICKNESS: .012 [.30]
 - 8) (BOXED) DIMENSIONS ARE CRITICAL TO PART FUNCTION
 - 9) {BRACKETED} DIMENSIONS ARE MAJOR INSPECTION DIMENSIONS

DRAWING IS IN INCHES AND [MILLIMETERS]	
TOLERANCES UNLESS OTHERWISE SPECIFIED	
3 PLACE DECIMAL ± .030	2 PLACE DECIMAL ± .05
2 PLACE METRIC ± .06	1 PLACE METRIC ± 1.3
ANGLES ± 1°	
DO NOT SCALE DRAWING	

THIS DRAWING CONTAINS CONFIDENTIAL & PROPRIETARY INFORMATION AND MAY NOT BE REPRODUCED IN WHOLE OR PART WITHOUT WRITTEN AUTHORIZATION FROM COMAR LLC	
NAME	DATE
KAD	05/24/17
CHECKED	03/30/17
ENG APPR	06/23/20

REV.	DESCRIPTION	DATE	APPROVED	DRN BY
B	ADDED MOLDBASE MB-2453 CONVERTED FROM SK-7642 REV A DRAWING NUMBER: 71-0010 WAS 5900 REVISED PART NUMBER TO VARIOUS FLOW: 170cc WAS 174cc REMOVED NOTES: MAX PERPENDICULARITY DEVIATION, MAX TAPER, LABEL PANEL WALL NOT TO EXCEED, AND TOP LOAD TO BE GREATER THAN OR EQUAL TO 90 LBS	6/23/20	BMG	MMR
A	ADDED STANDARD COMAR BLOCK	05/26/17	TKS	KAD
3	ECN# 1848, ADDED OPTIONAL BOTTOM VIEW FOR PCR	04/25/13		KAD
2	ENN# 1639, ADDED OPTIONAL BOTTOM VIEWS	03/26/04		AZ

TITLE		PART NO		SCALE
PZ-150 WIDE MOUTH ROUND BOTTLE WITH L38SP400 NECK FINISH		VARIOUS		1:1
COMMENTS		MOLD NO		REV
REF DWG #5900 (AM-18222-02)		MB2453, MB2412, MB2188, MB2223, MB2189		B
STATUS		SIZE	SHEET	DWG NO
STOCK		C	1 OF 1	71-0010

