

Target weight 30g

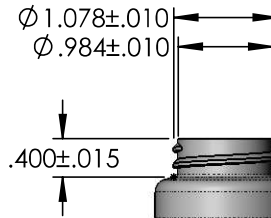

approx. fill level (16oz)

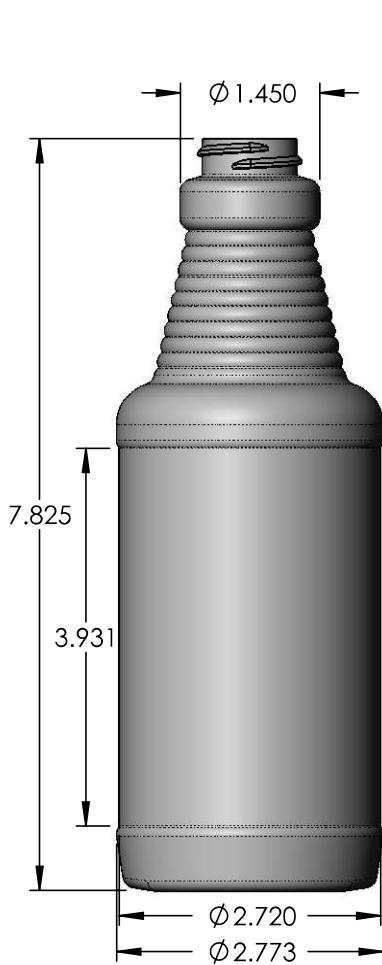
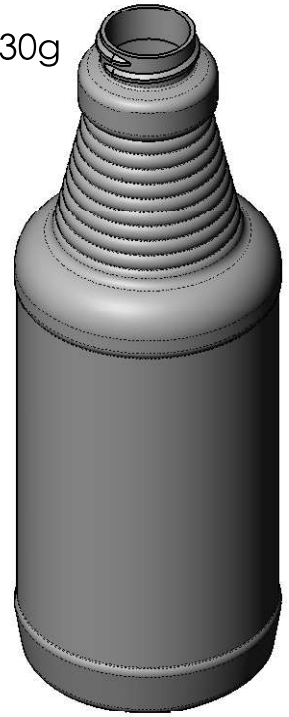
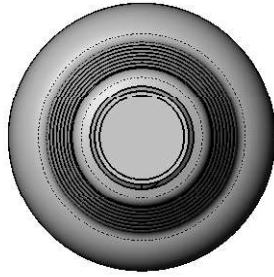
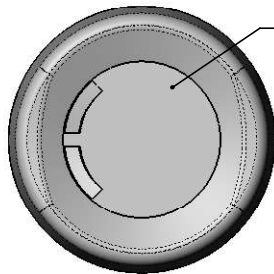

Recycle logo, Aaron's logo & cav. no. engraved.

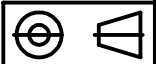

NOTE : SIZES ARE PRELIMINARY AND SUBJECT TO DEVELOPMENT

Unless otherwise specified

All dimensions are in inches

Tolerances :  
angular  $\pm 3^\circ$   
x.xx  $\pm 0.060''$   
x.xxx  $\pm 0.050''$

Project name : 16oz Carafe	
Material : HDPE	Customer :
Neck : 28-400	Fill vol. : 473ml
Scale 1 : 2	Overflow : 538ml +/- 13ml
<i>Aaron Packaging</i> 7817 South 210th Street Suite B101 Kent, WA 98032 (Phone) 253-872-4994 (Fax) 253-872-5184	
Drawn by : CML EW	Dwg.no. : 3504
Date : Sep. 10 2013	