

THIS DRAWING IS FOR DIMENSIONAL REFERENCE ONLY, COMPONENT PART MAY DIFFER VISUALLY DEPENDENT ON SPECIFICATION.

Fixture	ØA	ØB	ØC	D	Fixture Type
CMA 20/400	24,0	20,33	18,10	10,30	ribbed/smooth wall
CMA 20/410	24,0	20,33	18,10	13,60	ribbed/smooth wall
CMA 20/415	24,0	20,30	18,10	17,50	ribbed/smooth wall
CMA 22/415	26,0	22,30	20,10	19,0	ribbed/smooth wall
CMA 24/410	28,0	24,28	22,08	15,15	ribbed/smooth wall
CMA 24/415	28,0	24,58	22,08	23,0	ribbed

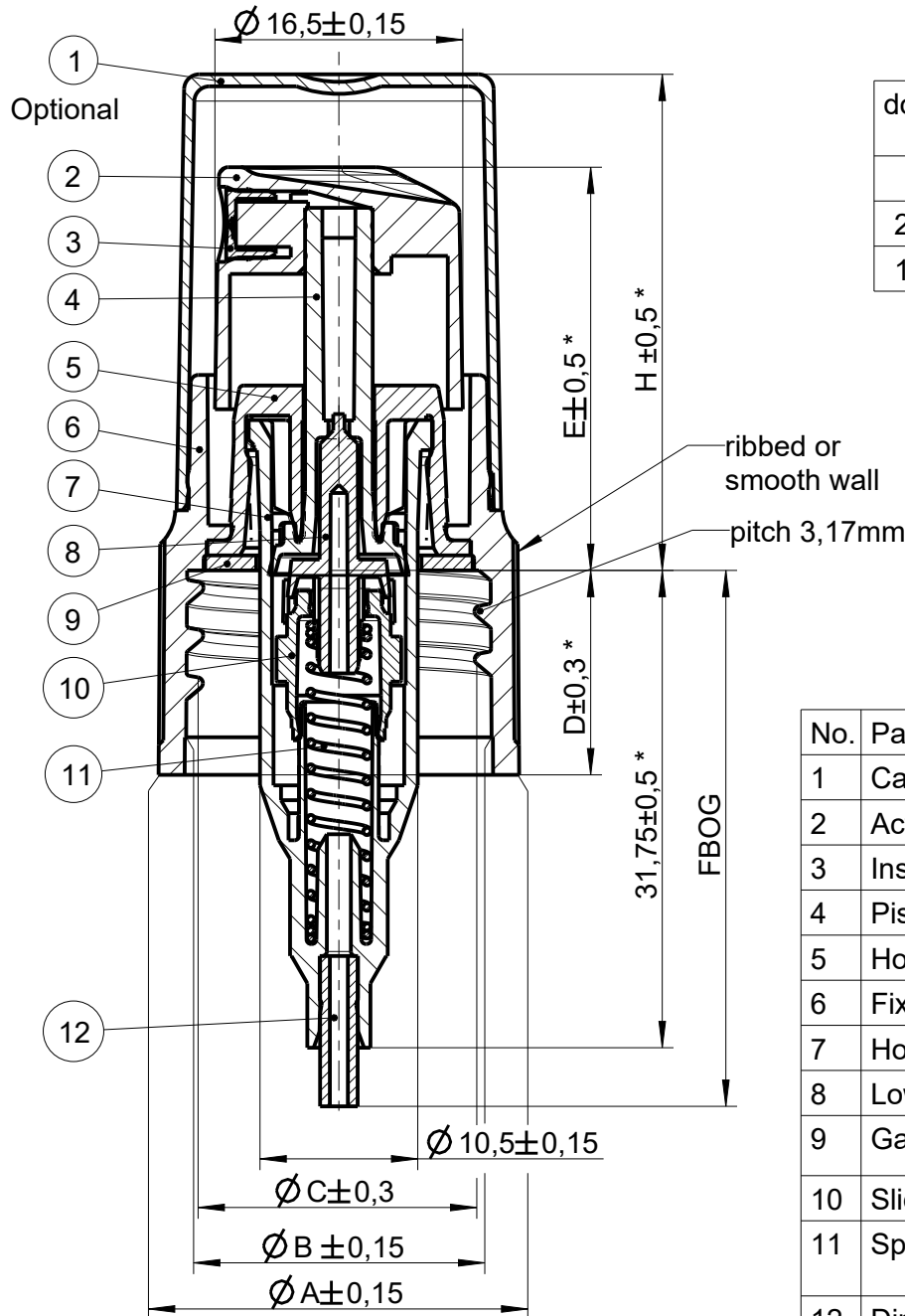

\*)Re.Std.-Gasket(1,0mm)

dosage	E	Stroke	Cap PKA24	Cap PKA22
			H	H
290µl	28,5	8,5	33,0	-
190µl	26,8	6,5	33,0	29,6

No.	Part	cosmetic	technical
1	Cap	PP	PP
2	Actuator	PP	POM
3	Insert	POM	POM
4	Piston	PE	PE
5	Housing cap	PP	POM
6	Fixture	PP	PP
7	Housing	PP	POM
8	Lower stem	PE	PE
9	Gasket	PE/EVA/ PE-Butyl/Rubber	PE/EVA/ PE-Butyl/Rubber
10	Sliding seal	PE	PE
11	Spring	Stainless steel	Stainless steel
12	Diptube	PP/PE-PP	PP/PE-PP

# Aptar

Title:

## PUMP\_ASM

PZ2 Dosage 190µl/290µl

Cap 22SH - 24LG / Act 001 / STD Fixture

DWG type:

CST

DWG size:

A4

Units:

MILLIMETERS

Scale:

2:1

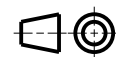

Sheet:

1/1

Drawn by:	B.SA.	01-Jul-97
Mod by:	B.Sasse	26-Jan-22
Checked by	B.Wanitschka	26-Jan-22

Descr. of Mod.

Update Frame and Table

Rev.:

R

Drawing Number:

CD-PZ02-0150

Status:

Approved