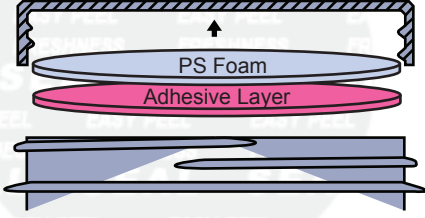

Uni-Foam™ Technical Data Sheet

PS-113

Revision: PS-113-07262013

Product	PS-113											
Scope	One piece uniform PS foam coated on one side with a specially formulated torque-activated adhesive. (Not approved for use with wet products.)											
Composition	<table border="1"> <thead> <tr> <th>Material</th> <th>Standard</th> <th>Metric</th> </tr> </thead> <tbody> <tr> <td>PS Foam</td> <td>0.020"</td> <td>0.508 mm</td> </tr> <tr> <td>Adhesive Layer</td> <td>0.002"</td> <td>0.051 mm</td> </tr> </tbody> </table>	Material	Standard	Metric	PS Foam	0.020"	0.508 mm	Adhesive Layer	0.002"	0.051 mm		
Material	Standard	Metric										
PS Foam	0.020"	0.508 mm										
Adhesive Layer	0.002"	0.051 mm										
FDA Status: 21 CFR 177.1210	Recommended Storage and Handling: Refer to website											
Drug Master File (DMF): 3948	EU / EP Reg.:											
GTR Oxygen:	MVTR:											
Print Location (if any):												

Selig materials are compliant with limitation of heavy metals in packaging per CONEG & EU 94/62/EC, article 11.

MSDS's are not required as Selig is not a chemical manufacturer or distributor and our products are 'articles' intended for food packaging per 29 CFR 1910.1200 (HazCom).

The information contained within this product data bulletin is to be used as a general guide in determining which structures are offered for sealing to specific container materials. All of the information which we provide is reliable to the best of our knowledge, but the accuracy thereof is not guaranteed. We suggest that consumers determine suitability for their own application.

www.seligsealing.com

Corporate Headquarters
Selig Sealing Products, Inc.
342 E Wabash St
Forrest, IL 61741, USA
Phone: +1 (815) 785-2100
Fax: +1 (815) 657-7584

North American Sales
Selig Sealing Products, Inc.
184 Shuman Blvd., Suite 310
Naperville, IL 60563, USA
Phone: +1 (630) 922-3158
Fax: +1 (630) 922-8469

European Sales and Manufacturing
Selig UK, LTD 635-637 Ajax Avenue
Slough Trading Estate
Slough Berkshire SL14BH UK
Phone: +44 (0) 1753 773 000
Fax: +44 (0) 1753 773 111

Canadian Manufacturing
Selig Canada, ULC
145 Edward Street
Aurora, Ontario Canada, L4G 1W3
Phone: +1 (905) 727-0014
Fax: +1 (905) 727-8544

Swiss Manufacturing
Selig Switzerland LTD
Bahnhofstrasse 11
CH-8172 Niederglatt
Phone: +41 (0) 44 851 50 50
Fax: +41 (0) 44 851 50 51



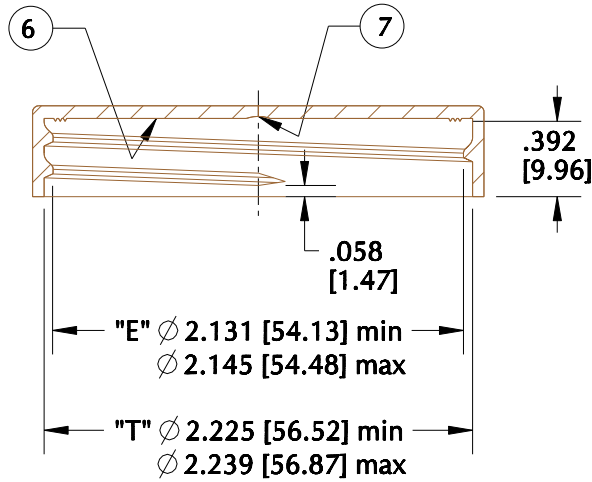
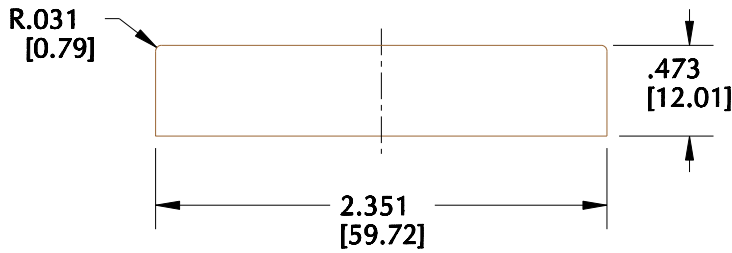
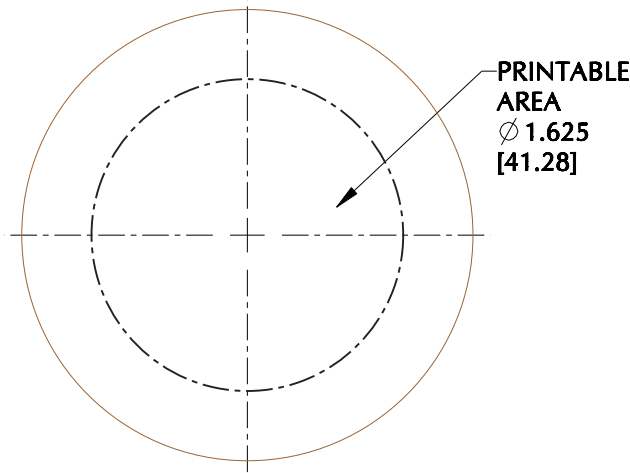

NOTES:

- 1. MATERIAL: POLYPROPYLENE
- 2. 6 THREADS/INCH
- 3. ALL FILLETS & RADII TO BE: .010" [.25] U.O.S.
- 4. TOLERANCES TO BE: ±.010" [.25] U.O.S.
- 5. DRAFT TO BE: 1/2° U.O.S.
- 6. CAVITY NUMBER
- 7. GATE LOCATION: INSIDE, CENTER
- 9. WEIGHT: APPROX. 6.7 GRAMS
- 9. PART #: 7175
- 10. [] BRACKET DIMENSIONS DENOTE METRIC

REV F - 10/28/17 - #RCT170476

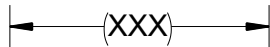

REFERENCE DIMENSIONS ARE NOT INSPECTED AND NO TOLERANCE APPLIED



INSPECTION DIMENSIONS ARE VERIFIED WITH TOLERANCE

THIS DRAWING IS NOT A CONTROLLED DOCUMENT IF PRINTED OR COPIED FROM THE APPROVED LOCATION

SIZE AND STYLE: CC58400SSJI		DRAWING TYPE: CUSTOMER			
DESCRIPTION: 58mm SMOOTH CLOSURE					
DRAWING NO: K7175-HS			PROJECT NO:		
CREATED BY: SM	CREATION DATE: 3/27/07	DRAWING REVISION: F	SHEET 1 of 1	SCALE: 1:1	SHEET SIZE A