



Laser+[®] C (C60A)

polyethylene terephthalate resin

Product Information

Product Description

Laser+[®] C (C60A) is a unique copolymer particularly suited for use in the custom PET container applications where clarity and neutral color are desired. It is a medium intrinsic viscosity (IV) product that gives the end user a strong clear bottle and offers excellent processing and consistency.

Typical Properties

Bi-orientation of Laser+[®] C (C60A) by injection/stretch blow molding provides optimal barrier and mechanical properties, including excellent vacuum performance. It performs well in both single- and two-stage processes used in the manufacturing of PET containers.

Laser+[®] C (C60A) offers excellent clarity and color, while maintaining good reheat characteristics for stretch blow molding. In addition, because it is a copolymer resin, it offers reduced crystallization rates and a wide processing window.

Certification

Laser+[®] C (C60A) is ideally suited for food packaging applications and is considered in compliance with the Food and Drug Administration (FDA) Food Contact Notification (FCN) 000635, covering PET polymers.

Sales Specifications

Property	Value	Unit	Test Method
Intrinsic Viscosity	0.83 ± 0.02	dL/g	DAK-QAR-SOP-0012
Color L*	87 ± 2.0	CIE	DAK-QAR-SOP-0011
Color b*	-3.0 ± 2.0	CIE	DAK-QAR-SOP-0011
Acetaldehyde	2 max	ppm	DAK-QAR-SOP-0010
Moisture Content (as packaged)	0.25 max	weight %	DAK-QAR-SOP-0013
Fines (as packaged, +24 Mesh Size)	0.10 max	weight %	DAK-QAR-SOP-0014
Chip Size, nominal	53 ± 5	chips / g	DAK-QAR-SOP-0015
Crystallinity	> 45	%	DAK-QAR-SOP-0016
Partical Size, Shape (Flat Cylinder)	3x3x2	mm	DAK-QAR-SOP-0017
Melting Point, nominal	246	°C	DAK-QAR-SOP-0016
Bulk Density	54.3	lb / ft ³	DAK-QAR-SOP-0018

These values represent the anticipated performance data for these polyester resins and intermediates; they are not intended to be used as design data. We believe this information is the best currently available on the subject. It is offered as a possible helpful suggestion in the experimentation you may care to undertake along these lines. It is subject to revision as additional knowledge and experience is gained. DAK Resins makes no guarantee of results and assumes no obligation or liability whatsoever in connection with this information. This publication is not a license to operate under, or intended to suggest infringement of, any existing patents.

CAUTION: Do not use in medical applications involving permanent implantation in the human body. For other medical applications, see "DAK Medical Caution Statement".



DAK Americas
ISO 9001:2008
#10004457

DAK Americas LLC
Gateway Corporate Center, Suite 210
223 Wilmington W Chester Pike • Chadds Ford, PA 19317
1-888-738-2002 • fax: 610-558-7385 • www.dakamericas.com

PDS-C60A Rev 06/11



Laser+[®] C (C60A)

polyethylene terephthalate resin

Product Information

Material Drying

Proper drying of polyethylene terephthalate (PET) is essential to produce a high quality part (container, film, etc.) with optimum physical properties. PET is hygroscopic, meaning that when it is exposed to humid atmospheres, it will absorb moisture. In PET the moisture is not only on the surface but diffuses slowly through the whole pellet and is firmly held by molecular attraction. Before processing the PET, this moisture must be removed. Carefully controlled drying of all PET is an essential requirement for optimum processing performance and final product properties. If drying is not carried out properly, to the known requirements of the type of PET in use, then deficiencies in process and product will result. The deficiencies will be impossible to remedy by later process changes. These defects arise in the injection molding or extrusion processes because at PET melt temperature (250°-280° C) any water present causes hydrolytic degradation of the PET, almost instantaneously, with the resultant loss in intrinsic viscosity (IV). Significant drops in IV cause loss of process control and reductions in end product properties.

Drying of PET polymer involves the diffusion of absorbed moisture from the interior of the polymer chip to its surroundings and, subsequently the removal of moisture from the bulk of polymer chips. Moisture removal can be achieved by heating the polymer chip under dry air or vacuum. In an air drying system, heated dehumidified air flows up through a chip bed and returns to the dehumidifier. The key requirements for a reliable drying process are:

Drying temperature: The ACTUAL chip temperature should achieve between 300° and 340° F measured at the dryer exit.

Dehumidified air temperature: Correctly designed equipment should operate at temperatures up to 340° F measured on entry to the dryer hopper, with an absolute maximum of 370° F to prevent possible discoloration.

Dehumidified air dew point: This should not be allowed to rise above -34° F and should preferably be -40° F or lower, measure after the desiccant bed. Always check the correct regeneration temperatures are being used.

Dehumidified air flow through the chip bed: Most dryers operate at around 1 cfm of airflow per 1lb/hr of PET chip as a minimum requirement, with the airflow at the correct temperature and dew point.

Chip residence time (drying time): DAK recommends a chip residence time for Laser+[®] PET of not less than four hours and preferably six hours. This is the theoretical drying time, which is calculated by dividing dryer capacity in lbs. by throughput in lb./hr. Extended periods of high temperature can adversely affect the polymer processing conditions. In the event of a stoppage for an extended period, dry polymer can be stored in the dryer-hopper by reducing the air temperature to 240° F (or even lower).



DAK Americas
ISO 9001:2008
#10004457

DAK Americas LLC
Gateway Corporate Center, Suite 210
223 Wilmington W Chester Pike • Chadds Ford, PA 19317
1-888-738-2002 • fax: 610-558-7385 • www.dakamericas.com

PDS-C60A Rev 06/11



NAN YA PLASTICS CORPORATION, AMERICA SOUTH CAROLINA PLANT

140 E BEULAH ROAD, LAKE CITY, SOUTH CAROLINA
P.O. BOX 939, LAKE CITY, SC 29560
TEL 843-389-7800 FAX 843-389-6894

Tairilin Chip General Specifications

Specification: CNGFA080
Description: A-grade Bottle Resin
Lot No: AA20

Property	Unit	General Specification	Test Method
A. IV (Intrinsic Viscosity)	dL/g	0.800 ± 0.02	NALC-QC-104
B. Color 1. L, Luminance 2. b, Yellowness		84.0 ± 3.0 -2.0 ± 3.0	NALC-QC-106
C. Melting Point	°C	246 ± 3	NALC-QC-115
D. Acetaldehyde Content	ppm	< 1.00	NALC-QC-410

1. Nan Ya PET resin complies with the U.S. FDA Code of Federal Regulations Title 21 part 177.1630 and EC Directive 2002/72/EC with respect to its use for food contact applications.

2. Typical drying conditions:

Maximum acceptable moisture level: 40ppm

Drying air temp: 160-180°C

Drying air dew point: < -40°C

Drying residence time: 4 - 6hours

3. Typical molding conditions:

Barrel temperatures: 275-285 °C

The conditions stated above are typical but not specific. Individual machine conditions will vary from machine to machine.

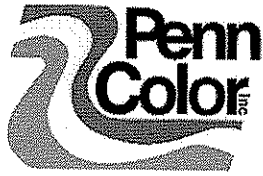

***Color Concentrates for Paradigm Packaging
Technical Data Sheet
(Typical Properties)***

Date:	Friday, January 08, 2010
Supplier:	Penn Color, Inc.
Supplier Code:	66W2117
Color:	White
Letdown Resin:	PET
Mix Ratio / Letdown Ratio:	2%
Pellet Size:	1/16" Strand-Cut Pellet
FDA Status (21 CFR):	Raw materials used in this formulation are listed in 21 CFR. See note*
Heavy Metals (CONEG):	This product was not formulated with Heavy Metal ingredients.

*Note: A FDA Letter can be provided by Penn Color's Regulatory Department upon request. However, be advised it is the responsibility of the user of this product to ensure compliance with all regulations that may impact their final product.

Please thoroughly test all Penn Color dispersion products in their final application prior to commercialization. Since finished formulations, and conditions of application, end use, and product exposures often vary considerably from those considered during the development and evaluation of a dispersion product, Penn Color can not assume the liability associated with product failure in use due to the lack of testing by the consumer. This sample is being sent to you under proprietary status. We appreciate that this product will not be analyzed or given to a third party for evaluation.

2801 Richmond Rd., Bldg. 2, Hatfield, PA 19440.

Phone 215-997-2221 Fax 215-997-8274

www.penncolor.com

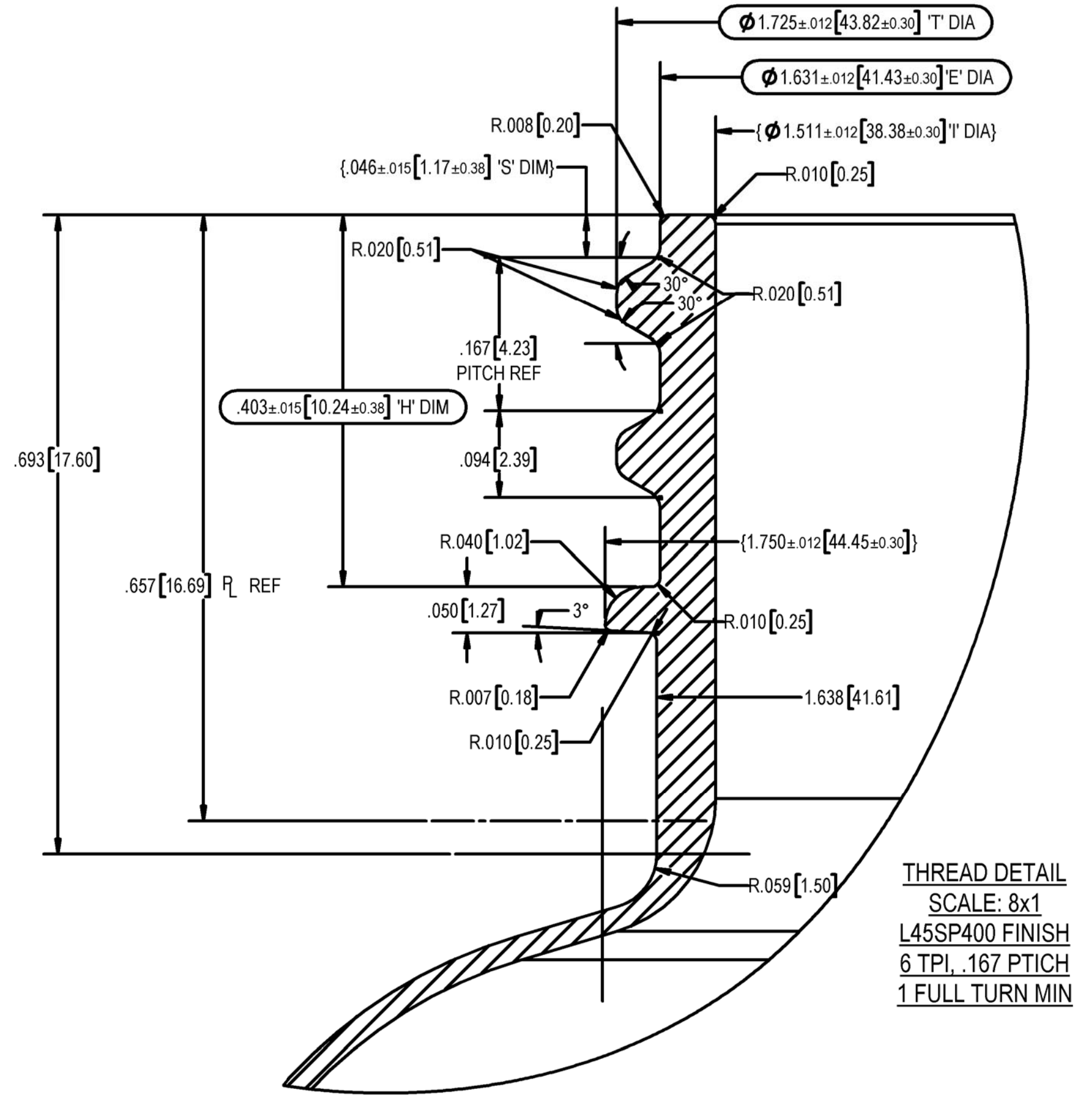
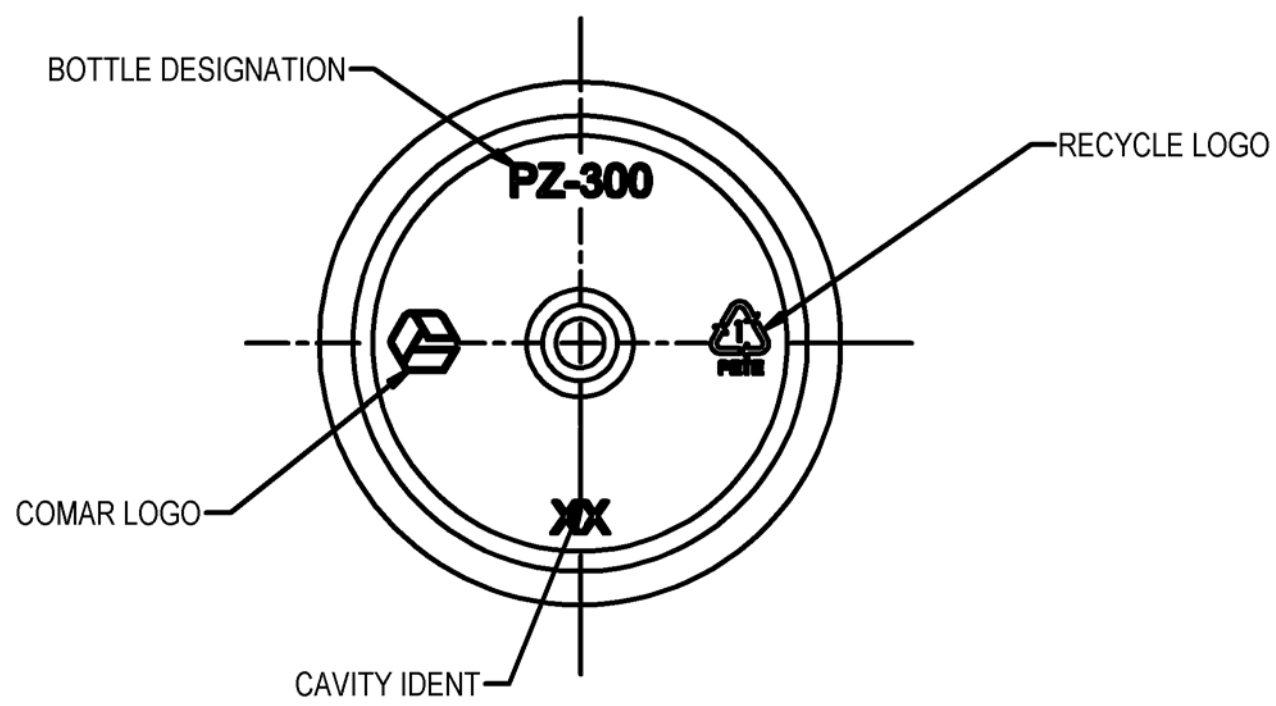
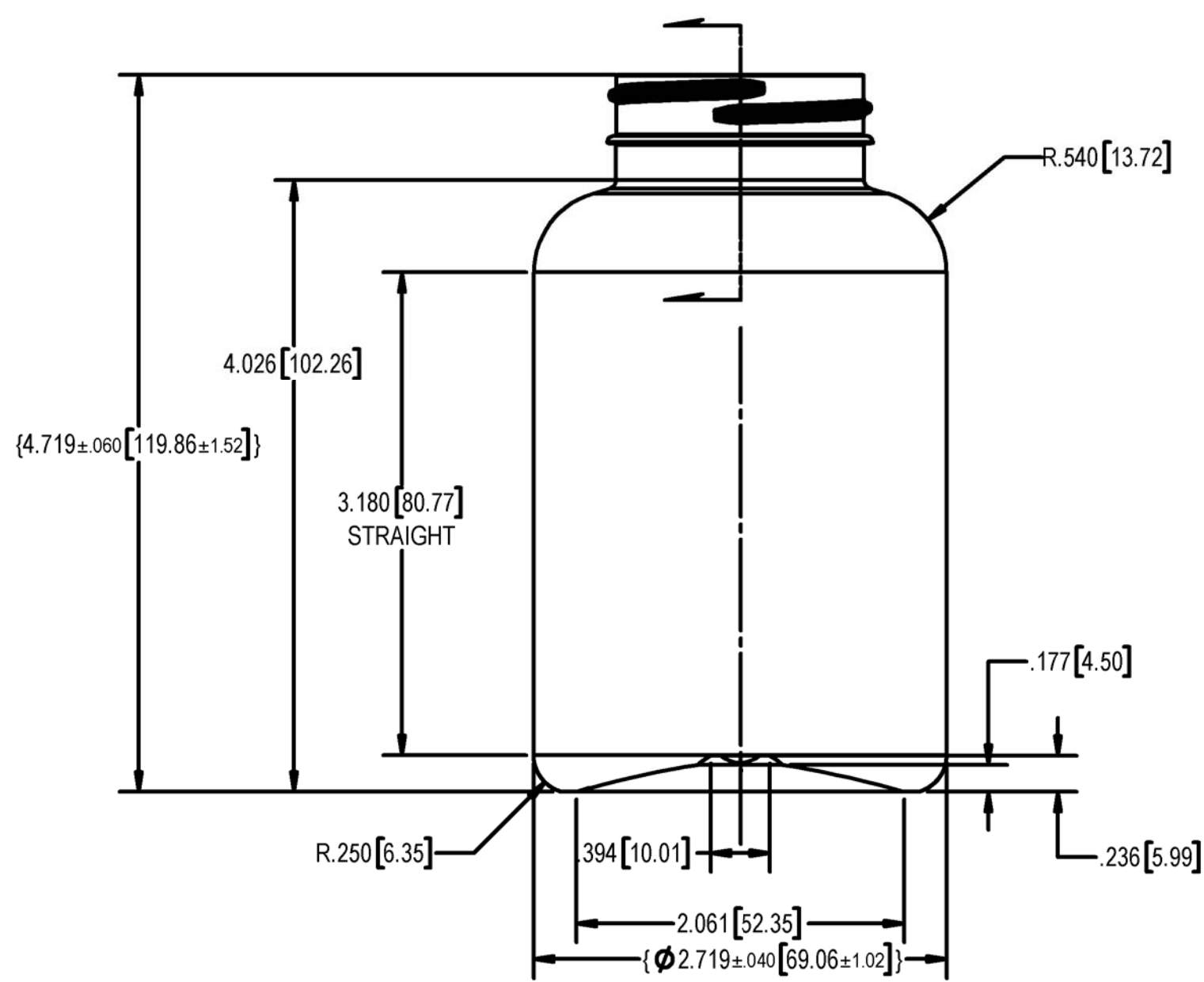

THREAD DETAIL
 SCALE: 8x1
 L45SP400 FINISH
 6 TPI, .167 PTICH
 1 FULL TURN MIN

NOTES:

- 1) GRAM WEIGHT: (30 GRAMS ±1.5 GRAMS)
- 2) CAPACITY: 364 mL ± 9 mL TO O'FLOW
- 2) DIMENSIONS SHOWN IN [] ARE EXPRESSED IN MILLIMETERS
- 3) FOR ALL UNSPECIFIED GEOMETRY, REFERENCE 3D MODEL FILE: 71-0027A_PZ-300 300mL Round 45-400
- 4) ALL SURFACES TO HAVE 'A2' FINISH UNLESS NOTED
- 5) (BOXED) DIMENSIONS ARE CRITICAL TO PART FUNCTION
- 6) (BRACKETED) DIMENSIONS ARE MAJOR INSPECTION DIMENSIONS
- 7) WALL THICKNESS VARIATION IN LABEL PANEL NOT TO EXCEED .012 inches [0.3mm], VERTICALLY OR RADIALLY
- 8) MAX TAPER = .003 inch [0.08mm] / 1 inch [25.4mm]
- 9) MAX PERPENDICULARITY = .005 inch [0.13mm] / 1 inch [25.4mm]
- 10) TOP LOAD > = 400N [90 LBS]
- 11) MIN WALL THICKNESS IN LABEL AREA = .016 inch [0.41mm]
- 12) MIN HEEL WALL THICKNESS = .012 inch [0.3mm]

REV.	DESCRIPTION	DATE	APPROVED	DRN BY
A	CAPACITY 364mL WAS 368mL GRAM WT 30g WAS 29g	6/6/2017		KAD

REV.	DESCRIPTION	DATE	APPROVED	DRN BY
	CONVERTED TO PRODUCTION ITEM FROM SK-6394 REV *	04/28/17		KAD

REV.	DESCRIPTION	DATE	APPROVED	DRN BY
	CONVERSION DESCRIPTION			

UNLESS OTHERWISE SPECIFIED

DRAWING IS IN INCHES AND [MILLIMETERS]

TOLERANCES

3 PLACE DECIMAL ± .020

2 PLACE DECIMAL ± .04

2 PLACE METRIC ± .50

1 PLACE METRIC ± 1.0

ANGLES ± -

CONCENTRICITY ± - T.I.R.

DO NOT SCALE DRAWING

THIS DRAWING CONTAINS CONFIDENTIAL & PROPRIETARY INFORMATION AND MAY NOT BE REPRODUCED IN WHOLE OR PART WITHOUT WRITTEN AUTHORIZATION FROM COMAR LLC

DRAWN BY	KAD	DATE	12/08/16
CHECKED		DATE	12/08/16
ENG APPR		DATE	06/07/17
MFG APPR			
QA APPR			

		ONE COMAR PLACE, BUENA, NJ 08310 1801 ANTONIO P BARCELO AVE, CAVEY, PR 00736 141 NORTH 5TH ST, SADDLEBROOK, NJ 07863 3217 PALME AVE, SHEBOYGAN, WI 53081 9519 JACKSON TRAIL RD, HOSCHTON, GA 30548 9177 CENTER AVE, RANCHO CUCAMONGA, CA 91730	
TITLE			
PZ-300, 300mL ROUND L45SP400 NECK FINISH			
MATERIAL	PET	CUSTOMER	STOCK
SCALE	1x1		
COMMENTS	REF SB 5152	PART NO	71-0027
HOLD NO	MB2273	SIZE	C
DWG NO	71-0027	SHEET	1 OF 1
REV	A		