

4

3

2

1

D

D

C

C

B

B

A

A

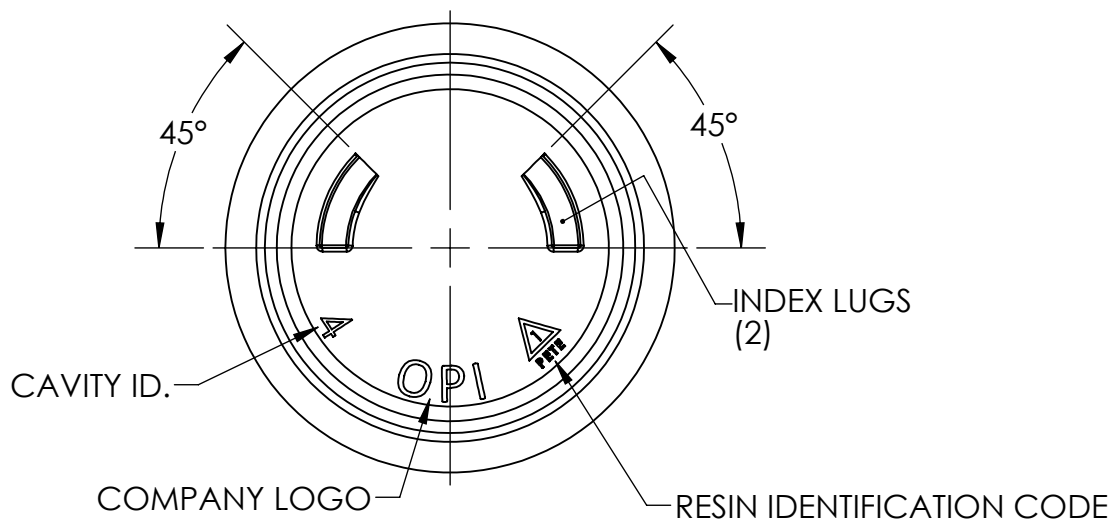
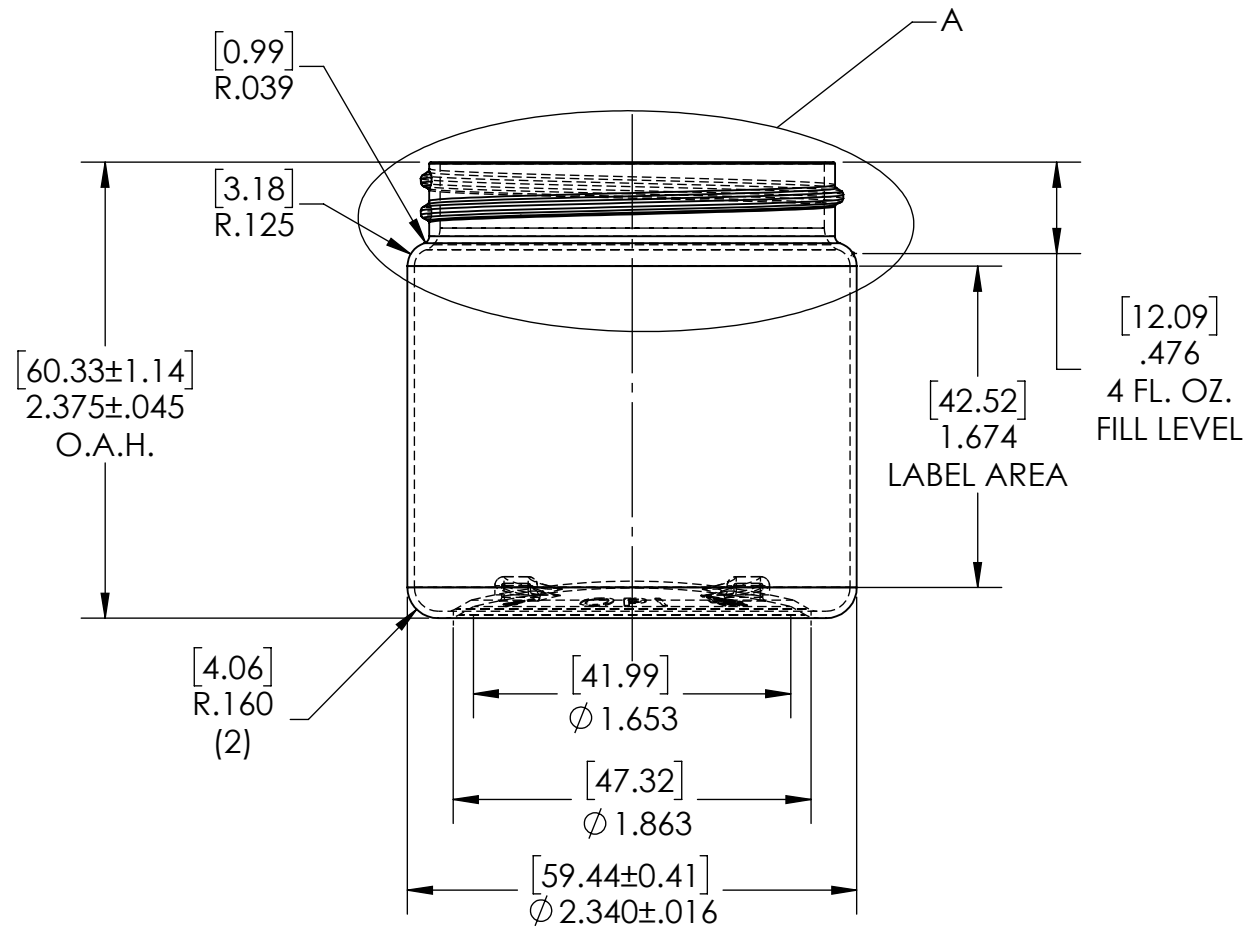
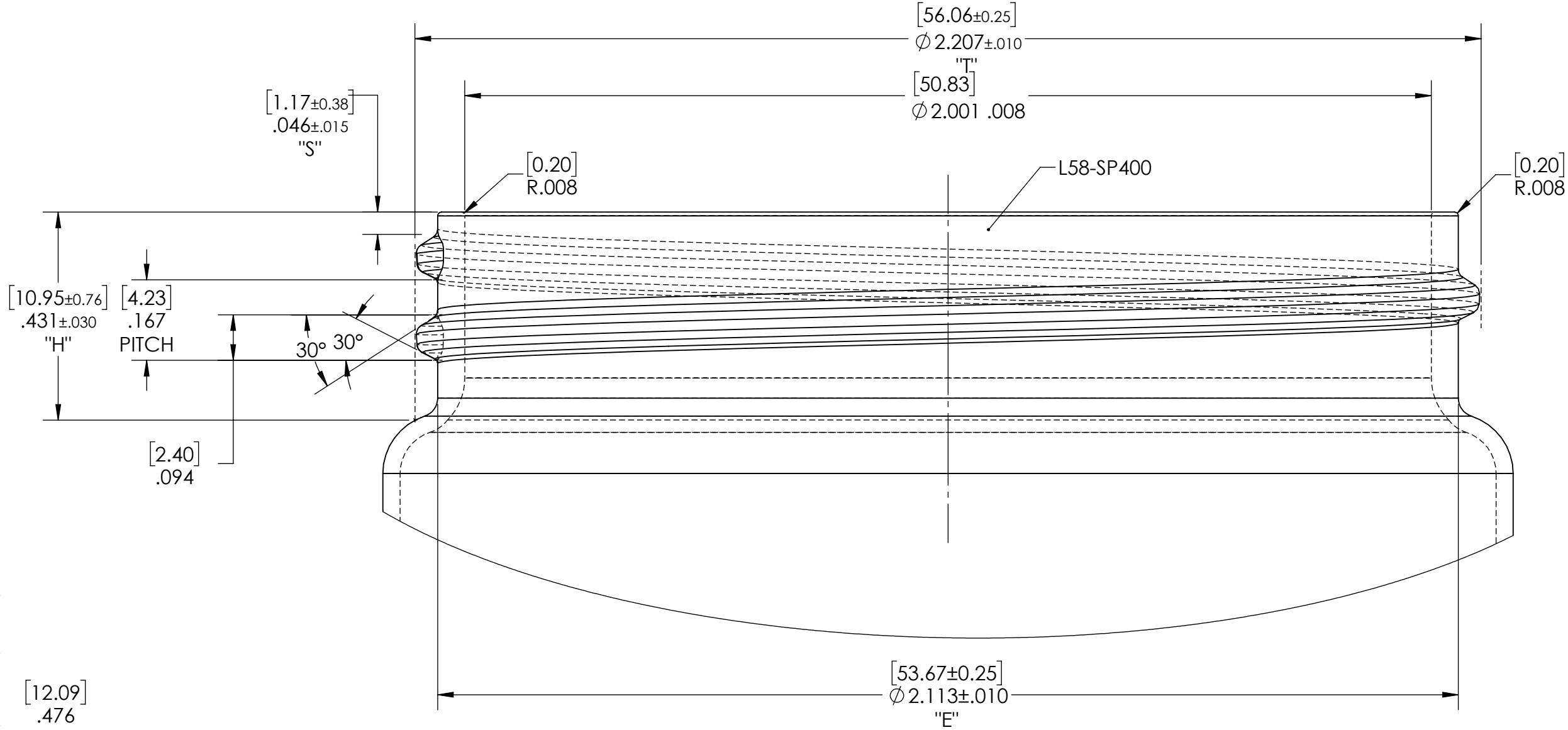
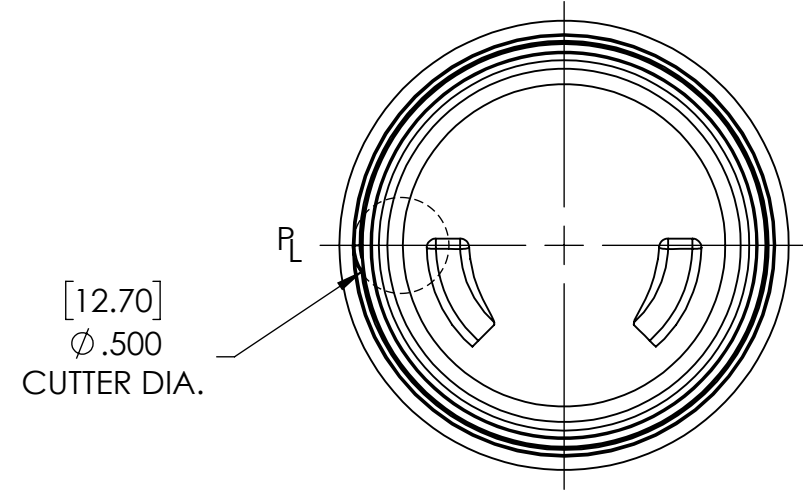

NOTE:
OVERFLOW CAPACITY 4.835 ±.17 FL.OZ. (FILL LEVEL FOR REFERENCE ONLY)



Part name: 4 FL.OZ. JAR W/M ROUND				
Project name: 4 FL.OZ. JAR W/M ROUND				
Material: PETE				
Weight: 18.9 ±.5 gr.				
Designed by: S. Loukov				
Approved by: B. KLOTZ				

ALL DIMENSION IN INCHES.GENERAL TOLERANCES ACCORDING TO DIN 16901

<input checked="" type="checkbox"/> INF Issued for Information	<input type="checkbox"/> IFA Issued for Approval	<input type="checkbox"/> IFC Issued for Construction	<input type="checkbox"/> IFP Issued for Production
---	---	---	---

Scale	Size	Drawing number	Rev.	Date
1:1	C	AY.0689	-	11/2/25

CONFIDENTIAL PROPERTY
The reproduction, use, or disclosure,
in whole or in part, of the design,
or details contained herein is prohibited without
prior written consent of Orange Products, Inc.

4

3

2

1