

TOP VIEW

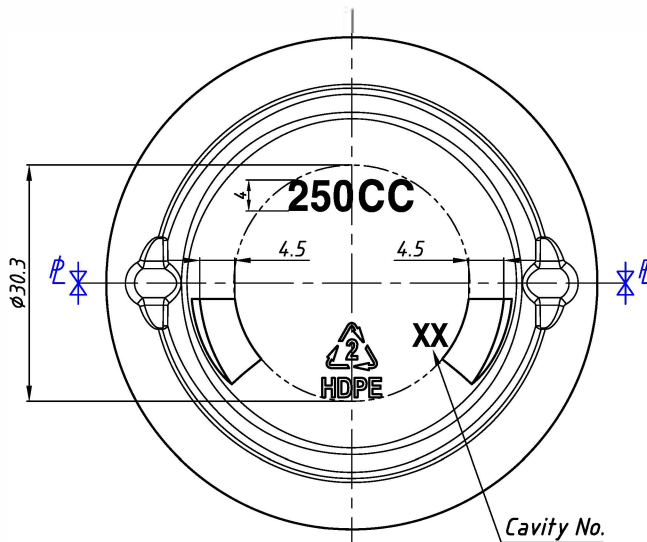
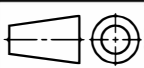

BOTTOM VIEW

| | | Date | | Modification | | | | |
|---|-----------------|---------------|---------------|-------------------|-------------|-----------------|-------------------|--------------|
| Position | Drawn | Checked | Approved | | | | | |
| Name | N.V.Trường | | | | | | | |
| Signature | | | | | | | | |
| Date | 18/09/2013 | | | | | | | |
| Title: | | | | | | | | |
| ROUND BOTTLE 250CC HDPE | | | | | | | | |
|  | Material | Weight | Volume | Drawing No | Page | Revision | Paper Size | Scale |
| | HDPE | 25.0gr±1.0 | 279ml±7 | 10513 | 1 / 1 | 00 | A4 | 1 : 1 |

TECHNICAL DATA SHEET KÖKSAN PET K-076

KÖKSAN

Koksan PET Resin is a general purpose food grade PET copolymer resin that is suitable for a wide variety of application like containers and films. Koksan Pet Resin offers an excellent strength characteristics like dimensional stability and mechanical properties.

Koksan PET Resin is suitable for injection, injection stretch blow molding and extrusion application mainly for carbonated soft drinks, water bottles, alcoholic beverages, households, oil, agrochemicals, wide mouth containers, PET sheets and film extrusion.

| Property | Unit | Value | Test Method |
|---------------------|-------------|-----------|--------------------------|
| Intrinsic Viscosity | dL/g | 0,76±0,02 | ISO 1628-5 |
| Acetaldehyde | ppm | max. 1 | ASTM F-2013-01 |
| Color L* | | min. 90 | ASTM D-6290 |
| b* | | Max.(+1) | |
| Melting Point | °C | 246±2 | DIN 53765 |
| Moisture Content | % | max. 0,2 | DIN 51777 Part 2 (09/74) |
| Chip Size | g/100 chips | 1,6±0,2 | IQ 10692 |
| Fines | ppm | max. 100 | IQ 10702 |

Specification KÖKSAN PET type K-076

Technology of Our Resin / Advantages

Pellet Shape / Spherical

Chips spherical shape
shape

Chips cylindrical



No dust generation during conveying

KÖKSAN PET Resin is produced using the latest state-of-art MTR technology with spherical pellet shape which ensures smooth conveying in long pipelines with near zero fines generation.

Save Energy during drying / injection process

The uniform spherical surface allow for easy flow of air around the PET pellets and not having any sharp corners helps in consistent drying at lower temperatures, saving valuable energy.

Document No RTDS-01
Issue Date 23.12.2015
Revision No/Date 3/5.2.2024
Page 1 / 2

KÖKSAN PET VE PLASTİK AMB. SAN. VE TİC. A.Ş. KÖKSAN PET PACKAGING INDUSTRY CO.

Address : Organize Sanayi Bölgesi, 83422 Nolu Cad. No:10 PK:39 Baspınar, 27600 Sehitkamil / Gaziantep / TURKEY
Tel : +90.342.3570330 Fax :+90.342.3570343-44 E-mail : info@koksan.com

Uniform IV within Resin Pellet

The final viscosity is reached in the melt phase by MTR (Melt-to-Resin) Technology. Since the reaction continues in the melt phase, the IV is uniform within pellet. This property gives the polymer easy melting behavior. In the conventional technology, the final viscosity is attained in SSP (Solid State Polycondensation) process. As it is known, the heat transfer coefficient of PET is very low. So, the viscosity is not uniform within pellet.

Low AA generation during drying and injection process

The low crystallinity and heat of the resin provides unique advantages of low residual acetaldehyde generation in injection process and also lower energy requirement for bottle production.

Low Dust Content in Resin Pellet

KÖKSAN latest state-of-art MTR with hot cutting technology ensures very low dust content in the resin pellets which helps superior product quality afterwards process.

Processing Conditions

The Processing condition depends on machines, product size and mold design.

| | |
|------------------------|-------------|
| Drying Temperatures | 160 -180°C |
| Drying Time | 4 – 6 hours |
| Injection Temperatures | 260 - 280°C |

Recommendation

We advise to our customers to use 8 – 12 C lower temperature and 30 – 60 min lower drying condition compare with the other PET resin which is produced with conventional SSP technology. In addition to drying process, decreasing temperatures around 8 – 12 C during injection process give better results in our standard injection application.

Remark

The above results confirm to our specification for type K-076.

All above mentioned results are based on KÖKSAN PET Resin Laboratory conditions and its analytical methods shown. Any other/different analysis methods or conditions may give other/different values. KÖKSAN PET Resin material will be accompanied by its Certificate of Analysis, with the relative representative average values of specified method/results.

KÖKSAN PET Resin shall not be responsible of the use of any products compliance, methods related to quality specifications and required regulations. No other warranty, either expressed or implied, regarding the suitability of the product for any particular purpose is made. Buyers must take their own determination about safety, health, environment protection and suitability of use for their intended purpose. No warranty is made of the merchantability or fitness of any products.

| | |
|------------------|------------|
| Document No | RTDS-01 |
| Issue Date | 23.12.2015 |
| Revision No/Date | 3/5.2.2024 |
| Page | 2 / 2 |

Mapolene 5502 is a high density polyethylene copolymer resin designed for applications requiring excellent stiffness and stress crack resistance properties. It may be used as a general-purpose blow molding resin or sheet extrusion thermoforming resin. This resin is also available with antistat.

Mapolene 5502

| | | |
|--------------------------------------|------------|------|
| Polyethylene Blow Molding | Melt Index | .35 |
| | Density | .955 |

| Properties ¹ | ASTM | Units | Value |
|---|------------|-------------------|---------|
| Melt Index (190°C/2.16 kg) | ASTM D1238 | g/10 min | .35 |
| Density | ASTM D1505 | g/cm ³ | .955 |
| Tensile Strength at Yield (2 in/min) | ASTM D638 | psi | 4000 |
| Elongation at Break (2 in/min) | ASTM D638 | % | >600 |
| Flexural Modulus | ASTM D790 | psi | 200,000 |
| ESCR Condition B, F ₅₀ (100% Igepal) | ASTM D1693 | h | 35 |
| Brittleness Temperature | ASTM D 746 | °F | <-180 |

This material meets the Food and Drug Administration requirements of 21CFR 177.1520.

¹Properties will vary and are not to be used for specification purposes.